



[www.fasep.it](http://www.fasep.it)

**User Manual**

User's Manual

V788

## VIDEOTRONIC V788.G3 USER MANUAL



For further information, please contact:

Email:

FASEP 2000 srl  
Via Faentina 96 - Ronta  
50032 Borgo San Lorenzo (Fi) Italy Tel.  
#39 055 8403126  
Fax #39 055 2691906

[www.fasep.it](http://www.fasep.it)  
[support@fasep.it](mailto:support@fasep.it)

## WARNINGS

*.This document contains information owned by FASEP 2000 srl and all rights are reserved, protected by copyright. This manual may not be photocopied or reproduced in any way without the written authorisation of FASEP 2000 srl.*

*FASEP 2000 srl reserves the right to update the firmware, software and documentation without any obligation to notify any person or company. The information contained in this document is subject to change without notice.*

*.Before installing the appliance described in this manual, the user must read this manual carefully to ensure they are fully informed about the installation, use and maintenance of the product.*

**Failure to read this manual and to comply with the instructions contained therein may result in injury to persons or damage to property.**





*FASEP 2000 srl cannot be held liable for any inconvenience, breakdowns or accidents resulting from an incomplete understanding of this manual or failure to follow the recommendations set out herein.*

*.FASEP 2000 srl cannot be held liable for any malfunctions, breakdowns or accidents resulting from unauthorised modifications to the appliance, or the use of non-original or unauthorised accessories (see the 'Accessories' section in this manual for a list of original accessories suitable for this model).*

**. FASEP 2000 srl cannot be held liable for any malfunction, breakdown or accident caused directly or indirectly by unauthorised technical interventions. Servicing by unauthorised technicians will invalidate the warranty and all rights of the owner.**

## AL CONVENTIONS USED

To help you find key information quickly and make the instructions easier to understand, this manual uses the following typographical conventions:

<b>&lt;BUTTON_NAME&gt;</b>	Used to indicate the name of the button on the control panel.
<b>DISPLAY</b>	Used to indicate text or a number visible on the display or control panel.
 <b>TIPS</b>	Contains useful tips or solutions, highlighted from the rest of the text.
 <b>NOTE</b>	Messages of this type contain important information, highlighted from the rest text.
 <b>WARNING</b>	Messages of this type appear in connection with procedures which, if not carried out can actually lead to data loss or cause damage to the equipment.
 <b>DANGER</b>	Messages of this type appear during procedures which, if not carried out correctly, may cause injury to persons or damage to property.

## ORIGINAL INSTRUCTIONS

### TABLE OF CONTENTS

WARNINGS.....	2
CONVENTIONS USED.....	2
1 INTRODUCTION.....	4
1.0 Intended use.....	4
1.1 Definitions.....	4
1.2 Lift - Intended use.....	4
2 INSTALLATION.....	5
2.1 Handling.....	5
2.2 Machine assembly.....	5
2.3 Installation.....	5
2.4 Electrical connection.....	5
2.5 Pneumatic connection (PL version only).....	5
2.6 Ignition.....	5
2.7 Lift connection.....	6
3 USING THE CONTROL PANEL.....	7
3.1 Meaning of the icons on the screen.....	7
3.2 Using the lift.....	10
4 CALIBRATION.....	11
4.1 How to calibrate the wheel balancer (USER).....	11
4.2 How to check the calibration and weight position (USER).....	12
5 ALU-SE calibration.....	13
6 SME calibration.....	14
7 MEASUREMENT AND CORRECTION OF UNBALANCE.....	15
7.1 Fitting the wheel onto the balancer.....	15
7.2 Entering the rim dimensions (dual-sensor version).....	15
7.3 Entering the rim dimensions (version with ALU-SE or LASER software).....	16
7.4 Measurement and correction of imbalance.....	16
7.5 How to apply the weight using the ALU-SE rod.....	17
7.6 How to apply the weight with the LASER.....	17
7.7 How to use the SPLIT programme.....	17
8 HOW TO PERFORM THE OPTIMISATION PROCEDURE.....	18
9 SPECIAL FUNCTIONS.....	19
9.1 Language selection.....	19
9.2 User Setup.....	19
APPENDIX.....	20
A: General Features.....	20
B: Environmental Data and Safety Requirements.....	21
C: Errors and Malfunctions Detected by the Computer.....	22
Q: How to safely remove the batteries from the product.....	23

## 1 INTRODUCTION

### 1.0 Intended use of the

This unit is designed to measure and correct static and dynamic wheel imbalances on vehicles whose dimensions and weights fall within the specified working range (see Appendix 'Technical Data').

This unit is intended for professional use. The operator must be properly trained before use. Training courses are not included in the price of the unit and can be purchased separately.

This unit is designed for use in indoor environments (see Appendix 'Environmental Specifications').



#### DANGER:

*This machine is designed for balancing vehicle wheels whose dimensions and weights fall within the specified working range (see Appendix 'Technical Data'). Special adapters are supplied for this purpose. It is strictly forbidden to use the machine to rotate anything other than a vehicle wheel. Inadequate clamping may cause rotating parts to become dislodged, damaging the machine, the operator or anything else in the vicinity.*

### 1.1 Definitions

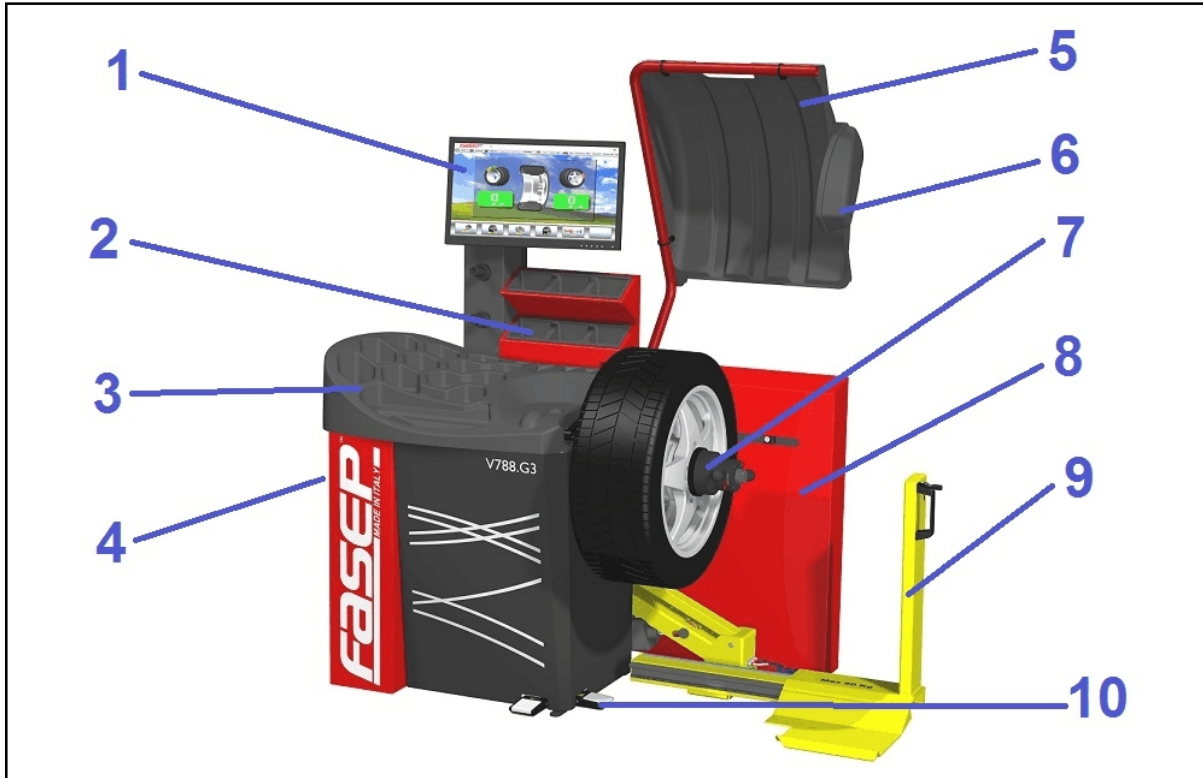

1. Monitor
2. Rear weight panel
3. Weight and tool holders
4. Side flange holders
5. Wheel cover

6. UL 3D Automatic Insertion Sonar
7. Quick-release handwheel + HD shaft
8. 3dWall
9. Pneumatic lift
10. Foot brake

### 1.2 Lift - Designed for use with

The lift on this machine has been designed for handling vehicle wheels complete with tyres, provided their dimensions and weights fall within the specified working range (see Appendix 'Technical Data').

This unit is intended for professional use.

The operator must be properly trained before use and must, in any case, read the "Operating and Maintenance Manual" carefully. This unit is designed for use indoors.

*- It is strictly forbidden to use the lift to lift or lower anything other than a vehicle wheel.*

*- Any use other than that specified is to be considered prohibited, not intended by the manufacturer and therefore potentially dangerous.*



## 2 INSTALLATION

### 2.1 Handling



**CAUTION:** *When moving the machine, never lift the balancer by the crankshaft or nearby parts.*

### 2.2 Assembly of the machine

To facilitate transport, the balancer is disassembled into several parts. Specific instructions will be provided if necessary.

### 2.3 Installation

The balancer must be secured to the floor and placed on a level surface.



**NOTE:** *Secure the machine to the floor using the four holes on the base and the screws provided.*

### 2.4 Electrical Connection



**DANGER:** *Failure to follow these instructions may cause damage to the machine or create an electrical hazard and will void the warranty.*

2.4.1 The electrical connection must be carried out by qualified personnel.

2.4.2 A wall-mounted switch is required. The switch must control the start and stop activate and provide overload protection for the machine's electrical circuit only. The device must be fitted with a residual current device (RCD) and a circuit breaker, in accordance with the power supply specifications of your balancing machine.

2.4.3 The machine must be connected using a plug.

2.4.4 The balancing machine must be effectively earthed. The electrical system is fitted with a suitable connection.

2.4.5 Ensure that the power supply specifications of your balancing machine (see label on the machine) are compatible with the electrical specifications of the external power socket.



**DANGER:** *Once connected, the machine is ready for operation. Always observe safety regulations carefully when using the machine (see the Appendices table for an overview of the main safety regulations).*

### 2.5 Pneumatic connection ( PL versions only)



**DANGER:** *Failure to follow these instructions may cause damage to the machine or create a hazard and will invalidate the warranty.*

1. *The connection must be carried out by qualified personnel, in accordance with local regulations and in line with current laws and regulations. Connections must comply with local regulations.*
2. *An external regulator lubricator with a condensate separator is required.*
3. *The machine's pneumatic circuit must be set to a minimum pressure of 6.5 atm - max 10 atm. Higher pressures could compromise the correct operation of the cylinder.*

#### 2.5.1 CONNECTION TO THE PNEUMATIC SYSTEM:

The machine is fitted with a universal connector, so no special or additional fittings are required. Insert a hose suitable for high pressures into the connector and check that it is securely locked in place.

### 2.6 Switching on

Connect the balancer to a 220V socket. To switch on the balancer, hold down the red (power) button until the indicator light comes on. To switch off the balancer, hold down the red (power) button until the indicator light goes out.

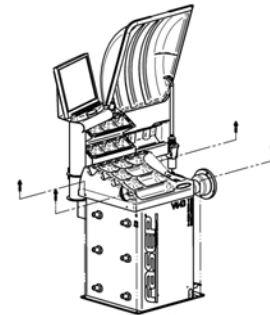
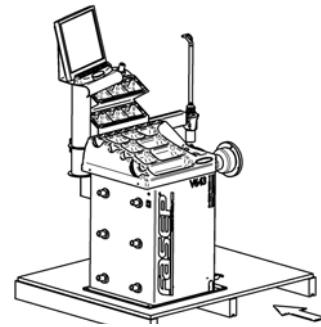

## 2.7 Connecting the t the lift

Connect the lift as shown in the figures below



### 3 USING THE CONTROL PANEL



Fig. 9 V643 control screen

#### 3.1 Meaning of the icons on the screen

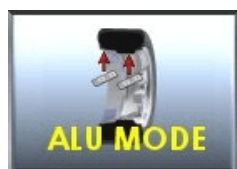

Fig. 10

Select the balancing mode



Fig. 13

Delete the last character when entering activation codes



Fig. 11

APS function



Fig. 14

Change selection



Fig. 12

Machine calibration

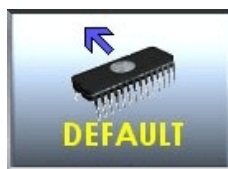

Fig. 15

Set default values



Fig. 16

Machine diagnostics



Fig. 23

Laser calibration



Fig. 17

Down button



Fig. 24

Return the rod laser to its resting position



Fig. 18

Position calibration



Fig. 25

Switch on the laser



Fig. 19

Return to previous page



Fig. 26

Fully extend the laser rod



Fig. 20

Fine resolution



Fig. 27

Manual measurement entry



Fig. 21

Access to the machine's Information Centre menu

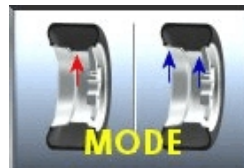

Fig. 28

Select Dynamic/Static



Fig. 22

Access to the measurements page



Fig. 29

Motion mode



Fig. 30

Confirm button

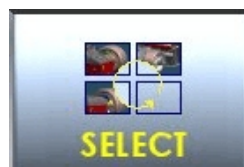

Fig. 37

Measurement selection



Fig. 31

Operator change



Fig. 38

Access to the machine setup menu



Fig. 32

Optimisation



Fig. 39

Skip the current operation



Fig. 33

Restart machine software



Fig. 40

Split function



Fig. 34

Reset partial statistics



Fig. 41

Stop the rotating wheel



Fig. 35

Reset of Peak-to-peak variations on the Sensor page



Fig. 42

Up button



Fig. 36

Save



Fig. 43

Scrolls through menus and selections (from top to bottom)

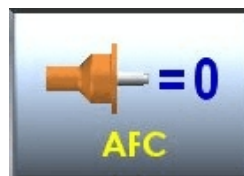

Fig. 44

Reset the Flange

### 3.3 Using the electric lift



1. Ensure the lift is on the ground > place the wheel on the lift > press START to measure the first wheel (ensure there is nothing between the top sonar and the wheel) > the lift automatically raises the wheel > push the lift towards the shaft so that the flange centres the wheel's central hole.

*Note: If the wheel is not perfectly centred on the flange, use the UP/DOWN buttons to adjust the lift. The adjustment will be saved automatically.*

2. After balancing the first wheel, press MEM to lower the wheel lift to the ground and save the wheel data to memory > for subsequent wheels, simply place them on the wheel lift and press MEM for perfect wheel centring

## 4 CALIBRATION

### 4.1 How to calibrate the (USER) wheel balancer



**NOTE:** The following symptoms indicate the need for calibration:

- a) an error in the calibration control programme
- b) consistently high and low weight readings
- c) the imbalance point is consistently incorrect
- d) more revolutions are required to balance the wheels



Fig. 46

Switch on the wheel balancer.

Select **SET UP > CALIBRATION > SET/OK > CALIBRATION > SET/OK**.

Start the machine with the shaft unloaded (Fig. 43)

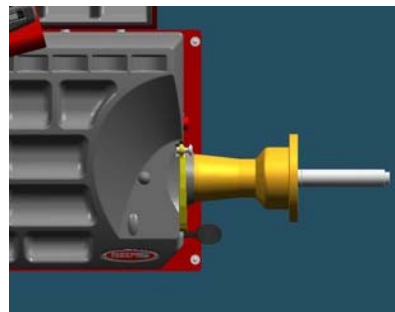

Fig. 47

Lower the cover or press **<START>**.

Once the spin is complete, insert a wheel (fig. 44) and lower the cover or press **<START>**.

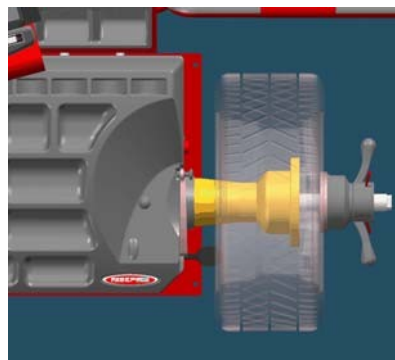

Fig. 48

Once the launch is complete, insert the calibration weight (Fig. 45) and lower the housing using the lever ( ) or press **<START>**.

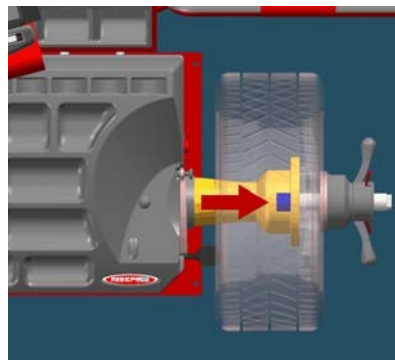

Fig. 49



**NOTE** Technical calibration is only available to qualified personnel.

#### 4.2 How to check the calibration and weight position (USER)



Fig. 50

Switch on the wheel balancer.

Select **SET UP > CALIBRATION > SET/OK > CHECK CALIBRATION > SET/OK**.

Insert the tyre and press **<START>** (Fig. 47).

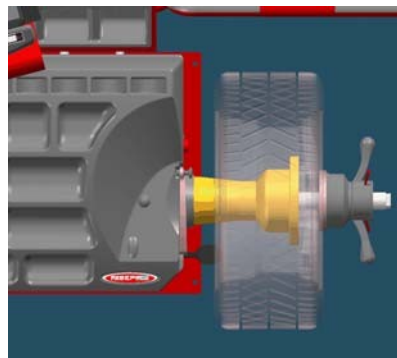

Fig. 51

Insert the calibration weight (fig. 48) and press **<SET/OK>**.

Lower the cover or press **<START>**.

At the end of the test cycle, **160-0** should appear (the permitted tolerance is  $\pm 10$ ).

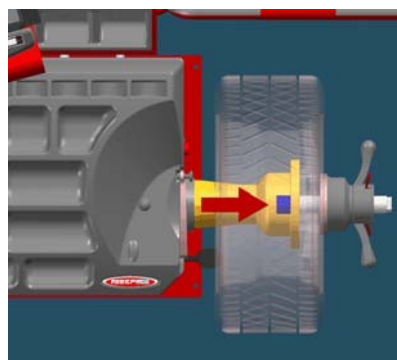

Fig. 52

Place the weight at the 6 o'clock position (Fig. 49) and check that only the green sector is displayed on the inner side. If this is not the case, press the **<6h>** button, place the weight at the 6 o'clock position, press **<SET OK>**.

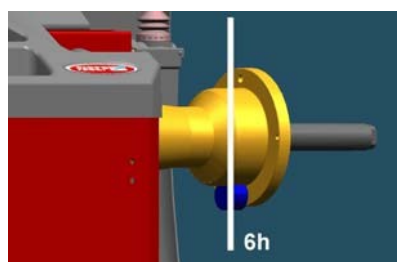

Fig. 53



**NOTE** *Technical calibration is available only to qualified personnel.*

## 5 ALU- SE calibration

Switch on the wheel balancer.

**MAIN MENU > MENU > RESET > CALIB > ALU-SE  
CALIBRATION > SET/OK**

Move the rod to the rest position (Fig. 50) and press **SET/OK**.

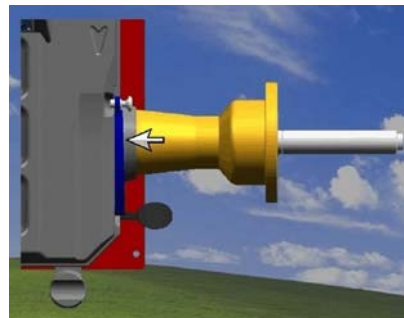

Fig. 54

Place the probe against the flange (fig. 51) and press **SET/OK**.

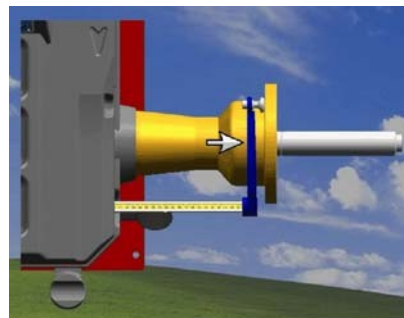

Fig. 55

Select the diameter of the wheel being tested

Place the rod on the inner side of the rim (fig. 52) and press **SET/OK**.

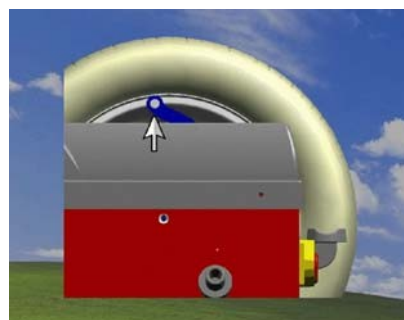

Fig. 56

Press **<ESC>** to return to the normal procedure.

## 6 r SME calibration

Switch on the wheel balancer.

**MAIN MENU > MENU > RESET > CALIB > SME  
CALIBRATION > SET/OK**

Leave the rod in the rest position (Fig. 53) and press **SET/OK**.

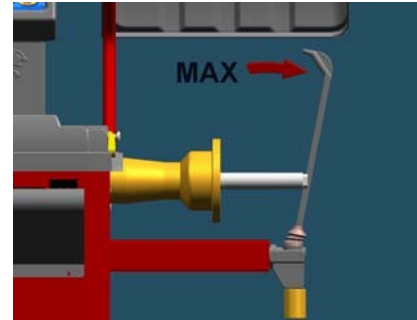

Fig. 57

Insert the rod (Fig. 54) and press **SET/OK**.

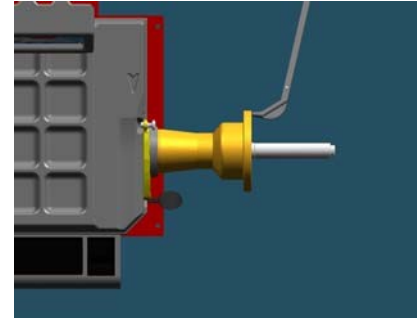

Fig. 58

Press **<ESC>** to return to the normal procedure.

## 7 MEASURING AND CORRECTING THE UNBALANCE OF THE

### 7.1 Fitting the wheel to the balancer

7.1.1 Carefully select the cone or flange for the wheel to be balanced.



**NOTE:** *Centring and clamping the wheel correctly is essential for proper balancing. Good results depend on these operations being carried out correctly. Clean the contact surfaces thoroughly before each operation.*



**DANGER:** *Always secure the flanges correctly to the drive shaft and the wheel to the flange used.*

### 7.2 Entering rim dimensions (dual- r probe version)



**NOTE:** The AUTOSELECT function allows automatic selection of the balancing mode (dynamic, ALU-S1, ALU-S2)

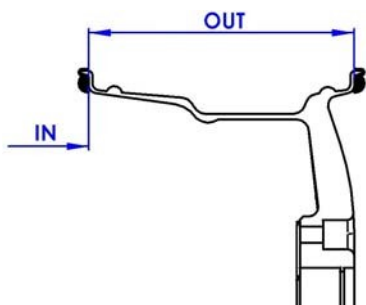

#### MAIN MENU

Measure the distance (fig.56).

Measure the width (Fig. 57).

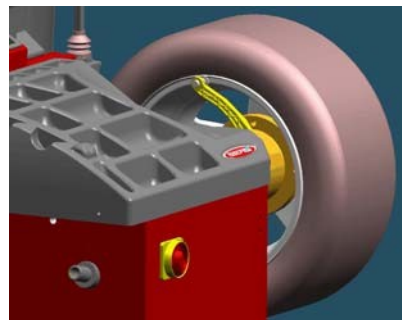

Fig. 60: Distance Measurement

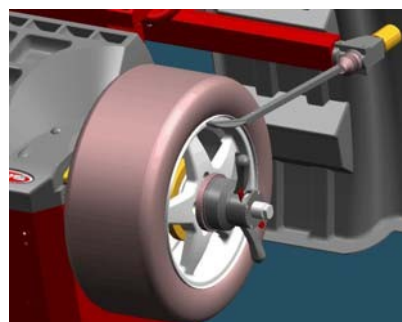
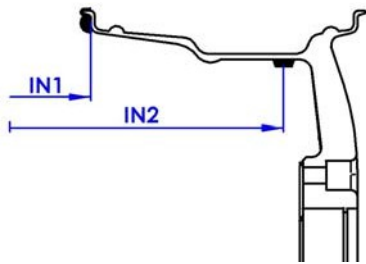

Fig. 61: Width Measurement

### 7.3 Entering the rim dimensions ( r ALU-SE version)



**DANGER:** *The laser mounted on the wheel balancer is Class 2; therefore, no specific protective measures are required. However, it is recommended that you avoid looking directly at the beam for prolonged periods.*



**MAIN MENU > INPUT**

Measure the point of application of the internal weight (IN1).

Measure the point of application of the external weight (IN2).

Fig. 62 ALU-S1

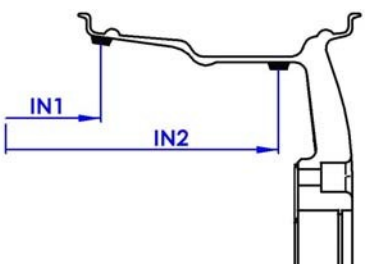

Measure the point of application of the internal weight (IN1).

Measure the point of application of the external weight (IN2).

Fig. 63 ALU-S2

### 7.4 Imbalance Measurement and Correction

7.4.1 After entering the wheel dimensions, press **<START>** or close the cover to start the wheel and detect the imbalance.



**DANGER:** *The wheel starts automatically when the cover is closed.*

7.4.2 At the end of the spin, the wheel will brake automatically. The screen will display the weight and position required to correct the detected imbalance.

7.4.3 Apply the weights (Fig. 60, Fig. 61). If the imbalance displayed is 0, press **<END>** to view the residual imbalance.



Fig. 64 inner side weight reading



Fig. 65 weight indication for outer side

### 7.5 How to apply the weight with the ALU- SE rod



Fig. 66

Place the weight on the rod (fig. 63).

Turn the wheel until the weight application position reached (fig. 62).

Move the rod until the weight application position reached (Fig. 64).

Apply the weight (Fig. 64).

Repeat the procedure for the other side.

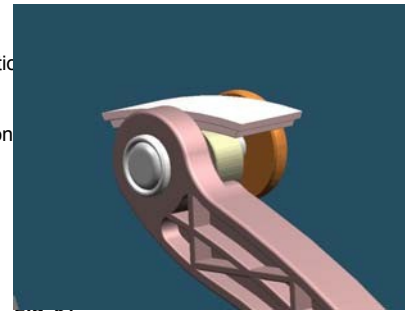

Fig. 67

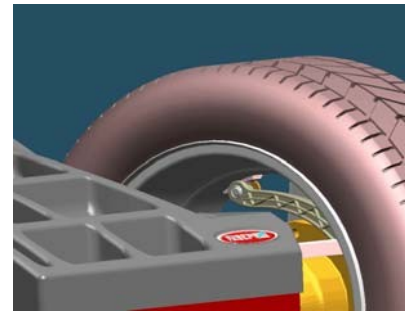

Fig. 68

### 7.6 How to apply the weight using the LASER-



Fig. 69

Turn the wheel until the two arrows on the inner or outer side turn green (fig. 65).

The laser beam will point to the weight application point (Fig. 66).

Apply the weight at the point indicated by the laser. Repeat the operation for the second side.

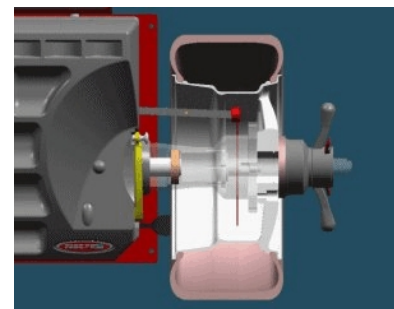

Fig. 70

### 7.7 How to use the SPLIT

After the control throw

Press <SPLIT> to select the programme.

Turn the dial until the indicator (green position) is at 12 o'clock. Press

<SET/OK> to confirm.

Turn the wheel until the second spoke (red position) is at 12 o'clock. Press

<SET/OK> to confirm.

Balance the wheel by placing the weights in the green and red positions.

## 8 HOW TO PERFORM THE OPTIMISATION PROCEDURE

### 8.1.1 MAIN MENU > OPTIMIZE

Measure the rim imbalance without the tyre (Fig. 67).

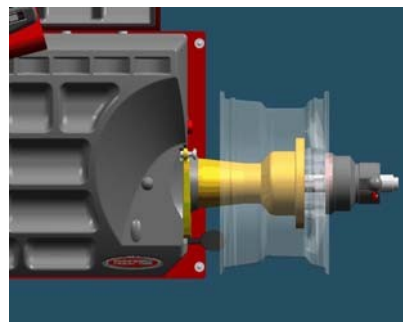

Fig. 71 first run, rim only

Fit the tyre to the rim and place the wheel on the balancer (fig. 68).

Start the balancing process.

Select the type of optimisation you wish to perform and follow the on-screen instructions.

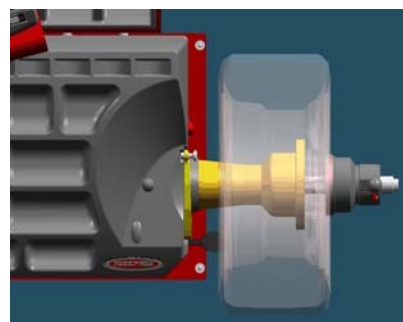

Fig. 72 Second run, complete wheel



**CAUTION:** *If flanges are used, they must remain attached to the rim whilst the tyre is being removed.*



**NOTE:** *Selecting the type of optimisation: the green field indicates the option recommended by the computer, i.e. the one resulting in the minimum amount of weights on the wheel. However, at the operator's discretion, to choose any of the three possible balancing solutions.*

## **9 L AND SPECIAL FUNCTIONS**

### **9.1 Selecting the language**

9.1.1 POWER ON > SET UP > USER SET UP > LANGUAGE > SET OK >.

9.1.2 Select the desired language and press SET OK.

### **9.2 User Setup**

9.2.1 POWER ON > SET UP > USER SET UP.

9.2.2 Select the desired option and press SET OK.

**APPENDIX**

**A: General Specifications**

<b>Power consumption</b>	400W	
<b>Balancing speed</b>	98 rpm	
<b>Complete cycle</b>	4–15 s	
<b>Measurement accuracy</b>	±1 gram (±1/28 ounce)	
<b>Acceptable wheel dimensions</b>	<b>Rim diameter</b>	8" (200 mm) – 26" (650 mm)
	<b>Wheel width (with wheel cover)</b>	max 16" (415 mm)
	<b>Wheel weight</b>	max 90 kg (198 lbs)

**Dimensions of the wheel balancer**

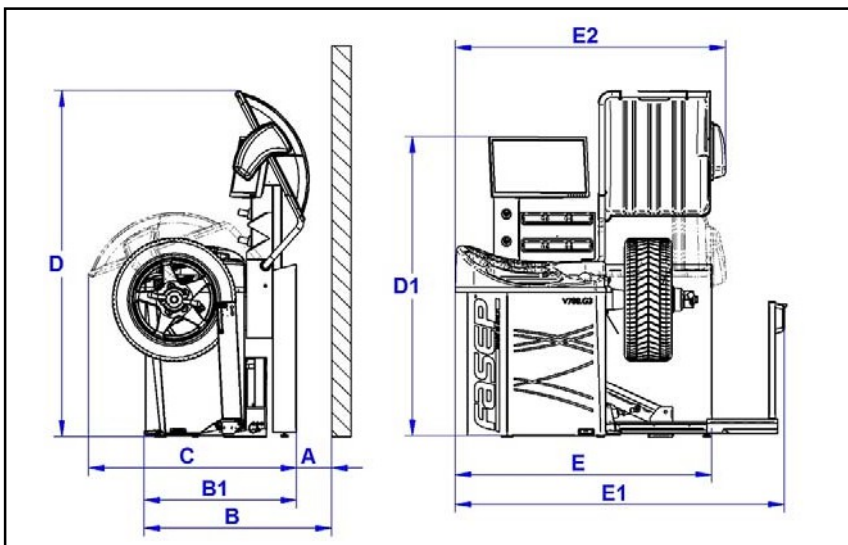

Dimensioni V788.G3	
A	300
B	1080
B1	780
C	1070
D	1770
D1	1530
E	1310
E1	1680
E2	1380
Dim Imballo	145x115x190 (cm)
Peso Lordo	250 kg
Peso netto	210 Kg

**Fig. 73:** Dimensions

**B: Environmental Data and Safety Requirements Environmental Data**

**[Operating Conditions]**

This unit is intended for indoor use only. Temperature: 0 to 45°C  
Relative Humidity: 5 to 80% at 40°C

**[Storage Conditions]**

The packaging is intended for indoor storage only. Temperatures:  
-25°C to 70°C  
Humidity: 5–95% at 40°C

**Safety characteristics**

1. The lead holder can be removed for servicing. It is secured to the machine body with screws, so that it can only be removed intentionally. Removal of this protective cover is restricted to authorised technical personnel only.
2. The control panel can be removed for servicing. It is secured to the machine body with screws so that it can only be removed intentionally. Removal of this guard is restricted to authorised technical personnel only.



**DANGER:** *The safety guard is still required when using the motorcycle kit.*

**WARNING** *FASEP 2000 srl shall not be liable for any inconvenience, damage or accidents caused directly or indirectly by unauthorised technicians. Any work carried out on any part by unauthorised personnel will invalidate the warranty and any rights the owner may have in respect of the machine.*



**NOTES:** *A safety guard is not required as the machine's rotational speed is less than 100 rpm. A safety guard is nevertheless recommended when balancing wheels with a diameter greater than 20".*

**General Safety Features**

*[Before using or servicing this machine]*

1. Read the instructions and the entire manual before using or servicing the balancer.
2. Ensure that the power supply complies with the specifications on the rating plate (see also the model identification plate).
3. Ensure that the machine is in a stable position.  
*[when using the machine]*
4. Protect the machine's power cables adequately.
5. When cleaning the area where the machine is used, ensure that the machine is properly protected.
6. Remove any stones and mud from the tyre before balancing the wheel.
7. Do not touch the wheel whilst it is spinning. Always use the protective guard for your safety.
8. Ensure that the balancing weights are securely attached before checking for residual imbalance. *[when servicing the machine]*
9. Ensure that the power supply is disconnected before carrying out any maintenance on the machine.
10. Servicing of circuit boards, electrical and mechanical parts must only be carried out by an Authorised Service Centre.

**C: Errors and Malfunctions recognised by the Computer-**  
Errors may only apply to certain models.

**ERR 1:** The shaft is not rotating

**ERR 2:** Incorrect direction of rotation

**ERR 3:** Unstable rotation speed

**ERR 4:** Incorrect rotation speed (too low/high) **ERR 5:**  
Position sensor/disc malfunction **ERR 6:** Guard cover  
open

**ERR 7:** Launch interrupted

**ERR 8:** Calibration weight not entered

**ERR 9:** Incorrect activation code

**ERR 10:** Full scale

**ERR 11:** Incorrect serial number

**ERR 12:** Serial number not entered

**ERR 13:** Reserved

**ERR 14:** Incorrect password

**ERR 15:** Error in E<sup>2</sup>PROM

**ERR 16:** Calibration not found

**ERR 17:** Rod in incorrect position

**ERR 18:** Required weight out of tolerance

**ERR 19:** Reserved

**ERR 20:** Reserved

**ERR 21:** Data entry error

**ERR 22:** The wheel is not being braked

**ERR 23:** Variation in weight due to vibrations

**ERR 24:** Reserved.

**ERR 25:** Reserved

**ERR 26:** Reserved

**ERR 27:** Insufficient pressure

**Q: How to safely remove batteries from the product.**



**Disposal of used batteries (applicable in all European Union countries and other European countries with separate collection schemes)**

This symbol on the product or packaging indicates that the battery must not be treated as normal household waste. By ensuring that batteries are disposed of correctly, you will help prevent potential negative consequences for the environment and health that could otherwise be caused by their improper disposal. Recycling materials helps to conserve natural resources. In the case of products which, for reasons of safety, performance or data protection, require a permanent connection to an internal battery, this must only be replaced by qualified service personnel. At the end of the product's life, take it to a suitable collection point for the disposal of electrical and electronic equipment; this ensures that the internal battery is also handled correctly. Dispose of used batteries at the designated collection points for recycling. For more detailed information on the disposal of used batteries or the product, please contact your local council or the local waste disposal service.

## VIDEOTRONIC V788.G3 USER'S MANUAL



For any information, please contact:

Email:

FASEP 2000 srl  
Via Faentina 96 50032  
Ronta (Fi) Italy Tel.  
#39 055 8403126  
Fax: +39 055 2691906

[www.fasep.it](http://www.fasep.it)  
[support@fasep.it](mailto:support@fasep.it)

## **WARNING**

*.This document contains information which is the property of FASEP 2000 srl and all rights are reserved. This manual shall not be photocopied or reproduced in any way without the prior written consent of FASEP 2000 srl.*

*FASEP 2000 srl reserves the right to revise product firmware, software or documentation without any obligation to notify any person or organisation. The information contained in this document is subject to change without notice.*

*.Before installing the unit described in this manual, the user should read this manual carefully to ensure they are properly instructed on the installation, use and maintenance of the unit.*

**Failure to read this manual and operate the unit accordingly may result in injury to the user or damage to the unit.**





*.FASEP 2000 srl shall not be liable for any inconvenience, breakdowns or accidents resulting from a lack of familiarity with this manual or the failure to follow the recommendations set out herein.*

*FASEP 2000 srl shall not be liable for any inconvenience, breakdowns or accidents resulting from unauthorised modifications to the unit or the use of non-original or unauthorised accessories (see the Accessories section in this manual for a list of original accessories available for this model).*

***.FASEP 2000 srl shall not be liable for any inconvenience, breakdowns or accidents caused directly or indirectly by unauthorised servicing. Servicing of any parts by unauthorised persons will invalidate the warranty and will void any rights of the unit owner.***

## **SYMBOLS AND CONVENTIONS FOR**

To speed up the retrieval of key information and make the instructions easier to understand, this manual uses the following typographical conventions:

<b>&lt;NAME OF THE PUSH BUTTON&gt;</b>	Used to indicate the name of push-buttons on the control panel.
<b>DISPLAY</b>	Used to indicate text or numbers visible on the displays on the control panel.
 <b>ADVICE</b>	Contains useful advice or solutions, highlighted in relation to the rest of the text.
 <b>NOTE</b>	Notes contain important information, highlighted compared to the rest of the text.
 <b>WARNING</b>	Warning messages appear in relation to procedures which, if not followed correctly, may result in data loss or damage to the unit.
 <b>CAUTION</b>	Caution messages appear in relation to procedures which, if not followed correctly, may cause injury to the user.

## ORIGINAL INSTRUCTIONS

### TABLE OF CONTENTS

WARNING .....	2
SYMBOLS AND CONVENTIONS .....	2
1 INTRODUCTION .....	4
1.0 Intended Use.....	4
1.1 Definitions.....	4
1.2 Lifter - Intended use .....	4
2 INSTALLATION .....	5
2.1 Moving the unit.....	5
2.2 Assembling the unit.....	5
2.3 Installation .....	5
2.4 Electrical connection .....	5
2.5 Compressed air connection (PL models only) .....	5
2.6 Power.....	5
2.7 Lifter connection .....	6
3 USE OF CONTROL PANEL.....	7
3.1 Meaning of the icons on the screen .....	7
3.2 How to use the electronic lifter .....	10
4.0 CALIBRATION OF WHEEL BALANCER .....	11
4.1 How to calibrate the wheel balancer (USER).....	11
4.2 How to check the calibration of the wheel balancer and position the weights (USER).....	12
5 Calibration ALU-SE .....	13
6 SME calibration .....	14
7 MEASUREMENT AND CORRECTION OF UNBALANCE .....	15
7.1 Placing the wheel rim on the wheel balancer.....	15
7.2 Input of Rim Dimensions (external measuring system version).....	15
7.3 Input of Rim Dimensions (ALU-SE or LASER version).....	16
7.4 Detecting and correcting imbalance.....	16
7.5 How to apply the weight using the ALU-SE applicator.....	17
7.6 How to apply the weight using LASER .....	17
7.7 How to use the SPLIT programme .....	17
8 HOW TO OPTIMISE WHEEL BALANCE .....	18
9 SPECIAL FUNCTIONS .....	19
9.1 Language selection .....	19
9.2 Setup.....	19
APPENDIX.....	20
A: Technical data .....	20
B: Environmental Data, Safety Features and Requirements .....	21
C: Errors and Malfunctions Detected by the Computer .....	22
Q: How to safely remove the battery from the product .....	23

## 1 INTRODUCTION

### 1.0 Intended Use

This unit is designed to measure and correct static and dynamic imbalance in vehicle wheels, the dimensions and weight of which fall within the machine's operating range (see the 'Technical Data' appendix for reference)  
This unit is intended for professional use. Operators must be properly trained before use. The training course is not included in the price of the unit and must be purchased separately.  
This unit is designed for indoor use only (see the "Environmental Data" appendix for reference).



#### CAUTION:

*This unit is designed to spin vehicle wheels only, within the approved range of dimensions and weight (see the "Technical Data" appendix for reference). Special adaptors are provided for this purpose. Do not attempt to use the machine to spin anything else. Improper locking may cause the part being spun to be ejected, causing damage to the unit itself, the operator or anything in the vicinity.*

### 1.1 Definitions

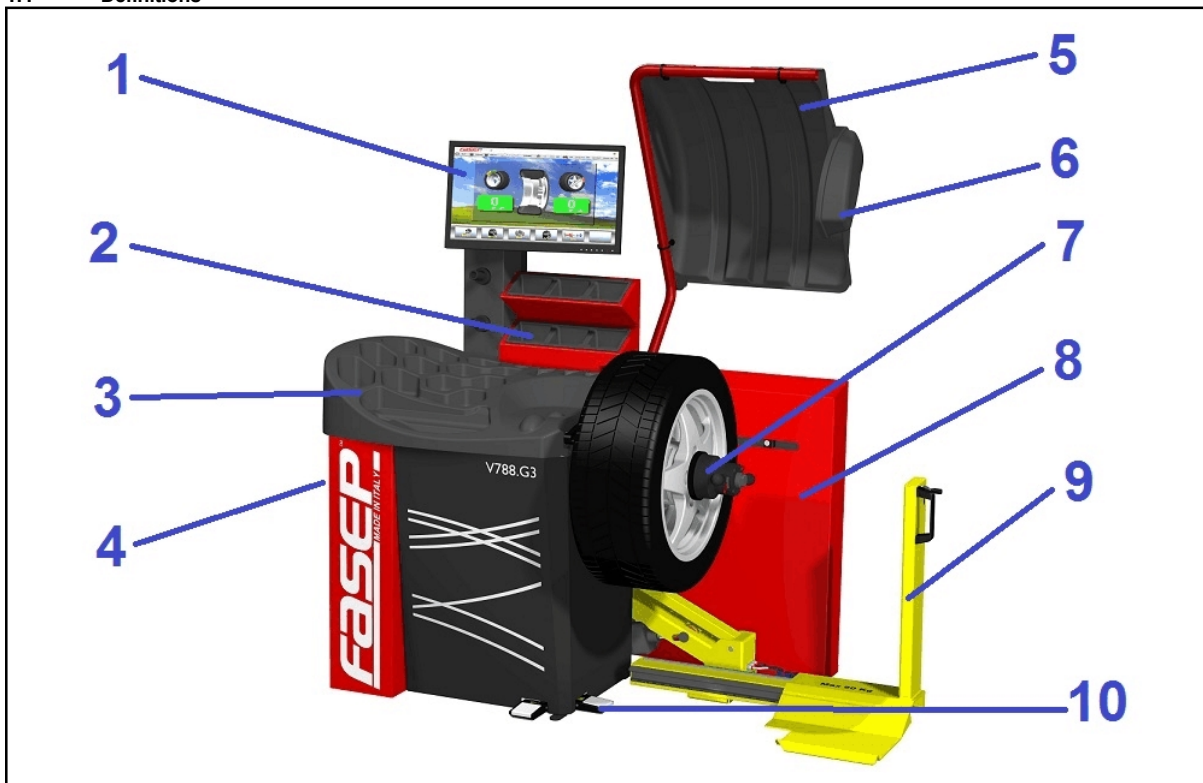

- |                                     |                                |
|-------------------------------------|--------------------------------|
| 1. Monitor                          | 6. UL 3D Automatic Input Sonar |
| 2. Rear-mounted weight compartments | 7. Quick lock + HD shaft       |
| 3. Weights and tools trays          | 8. 3dWall                      |
| 4. Side flange holders              | 9. Pneumatic lifter            |
| 5. Wheel guard                      | 10. Foot pedal                 |

### 1.2 Lifter - Intended for use with

The lifting mechanism of this wheel balancer is designed to lift vehicle wheels complete with tyres, provided their size and weight fall within the specified working range (see Appendix 'Technical Data').

This unit is intended for professional use. Operators must be properly trained before use and must, in any case, carefully read the 'User's Manual'. This unit is designed for indoor use.



*- It is strictly forbidden to use the lift to move, raise or lower anything other than a vehicle wheel.  
- Any use other than those specified shall be deemed prohibited, not intended by the manufacturer and therefore potentially dangerous.*

## 2 INSTALLATION

### 2.1 Moving the unit



**WARNING** *When the unit needs to be moved: never lift the balancer by the motor shaft or in its vicinity.*

### 2.2 Assembling the wheel

For ease of transport, the wheel balancer may be disassembled into units. If necessary, assembly instructions are provided in each package.

### 2.3 Installation

The wheel balancer must be installed on firm, level ground.



**NOTE:** *The machine must be secured to the floor using the four holes in the base and the anchor bolts provided*

### 2.4 Electrical Hookup



**CAUTION:** *Failure to follow these instructions may result in damage to the unit or create an electrical hazard and will void the warranty.*

2.4.1 The electrical connection must be carried out by a qualified electrician.

2.4.2 A wall-mounted fuse box is required at the installation site. This switch should provide on-off control and overload protection for your wheel balancer only. The fuse box should be fitted with time-delay fuses in accordance with the power rating specified for your wheel balancer.

2.4.3 The machine must be connected using plug connectors.

2.4.4 The balancer must be effectively earthed. The power cord is usually fitted with an earth terminal.

2.4.5 Ensure that the power rating specifications for your wheel balancer (refer to the nameplate on the wheel balancer) match those of the external power source.



**CAUTION** *Once the electrical connection has been made, the unit is ready for operation. Always observe the relevant safety precautions when operating the unit (see the tables in the Appendix for an overview of the relevant safety requirements).*

### 2.5 Compressed air connection (PL models only)



**CAUTION** *Failure to follow these instructions may result in damage to the unit or create a hazard and will void the warranty.*

1. *The compressed air connection must be carried out by a qualified technician, in accordance with local safety requirements and relevant national standards and regulations. All fittings and hoses must comply with local codes.*
2. *A wall-mounted lubricator and water separator is required at the installation site.*
3. *The compressed air supply to the balancer must be regulated to a pressure of between 6.5 atm and 10 atm. Excessive pressure could impair cylinder operation.*

#### 2.5.1 CONNECT TO AIR SUPPLY:

The machine is fitted with a universal connector and therefore no other special or additional fitting is required. Push a high-pressure rubber air hose all the way onto the connector and secure it.

### 2.6 Power

Plug the wheel balancer into a 220V socket. To switch on the wheel balancer, press the red button (power) until the indicator light comes on. To switch off the wheel balancer, press the red button (power) until the indicator light goes out.

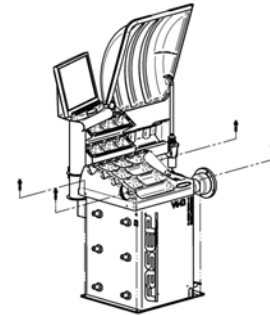
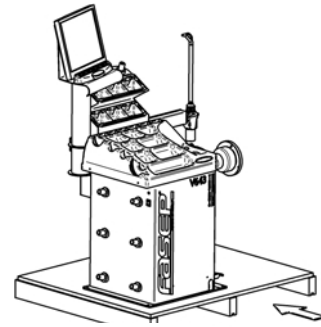

## 2.7 -Hookup Lifter

Connect the lift as shown in the figures below

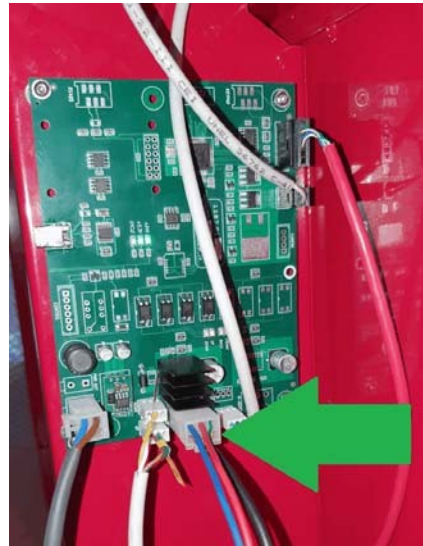

### 3 USE OF THE CONTROL PANEL



Fig. 9 Panel V643

#### 3.1 Meaning of the icons on the screen

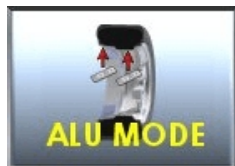

Fig. 10

Select balancing mode



Fig. 13

Delete last character in input activation code



Fig. 11

APS Function



Fig. 14

Change selection



Fig. 12

Calibration

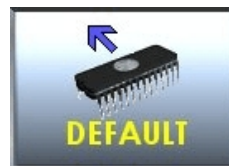

Fig. 15

Set default values



Fig. 16

Diagnostic



Fig. 23

Laser calibration



Fig. 17

Key down



Fig. 24

Place the rod laser in the rest position



Fig. 18

Position calibration



Fig. 25

Start laser



Fig. 19

Go to the previous page



Fig. 26

Pull the rod laser out fully



Fig. 20

High resolution



Fig. 27

Manual input of measurements



Fig. 21

Access to Information Centre

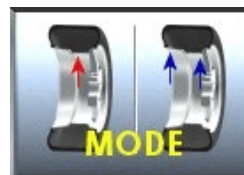

Fig. 28

Set Dynamic/Static



Fig. 22

Page access statistics



Fig. 29

Motion mode



Fig. 30

SET/OK key

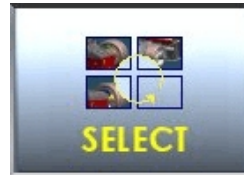

Fig. 37

Set measures



Fig. 31

Double operator



Fig. 38

Go to setup menu



Fig. 32

Optimize



Fig. 39

Skip current operation



Fig. 33

Restart software



Fig. 40

Split function



Fig. 34

Reset partial statistics



Fig. 41

Stop turning the wheel



Fig. 35

Reset page sensor settings

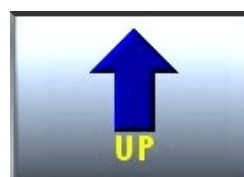

Fig. 42

Key up



Fig. 36

Save



Fig. 43

View menu and selection  
(UP/DOWN)

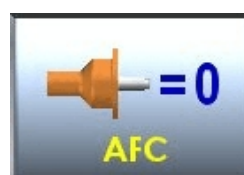

Fig. 44

Automatic flange calibration

### 3.2 How to use the electronic- lifter



1. Ensure the lifter is on the ground > position the wheel on the lifter > press START to measure the first wheel (ensure there is nothing between the top-mounted sensor and the wheel) > the lifter automatically raises the wheel > push the lifter towards the shaft so that the flange centres the wheel's central hole.

*Note: if the wheel is not perfectly centred on the flange, please use the UP / DOWN buttons to adjust the lifter. The adjustment will be automatically saved.*

2. After balancing the first wheel, press MEM to lower the wheel balancer to the floor and save the wheel data to memory > for the following wheels, simply place them on the wheel balancer and press MEM to centre the wheel perfectly

## 4.0 CALIBRATION OF THE WHEEL BALANCER

### 4.1 How to calibrate the wheel balancer (USER)



**NOTE:** *the following symptoms indicate a need for calibration:*

a) *the calibration check fails.*

c) *the indicated point of imbalance is consistently incorrect*

b) *consistently low or high weight readings.*

d) *more than two spins required to balance the wheels repeatedly.*



Fig. 46

Switch on the wheel balancer.

Select **SET UP > CALIBRATION > SET/OK > CALIBRATION > SET/OK**.

Spin with no wheel on the shaft (Fig. 43)

Close the wheel guard or press **<START>**.

At the end of the spin, place a wheel (Fig. 44) and close the wheel guard or press **<START>**.

At the end of the spin, place the calibration weight (Fig. 45) and close the wheel guard or press **<START>**.

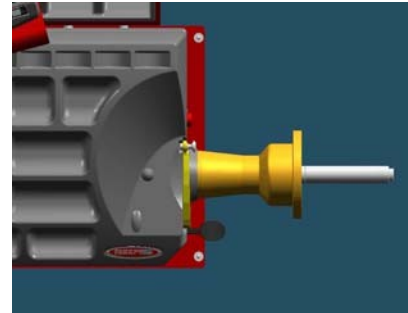

Fig. 47

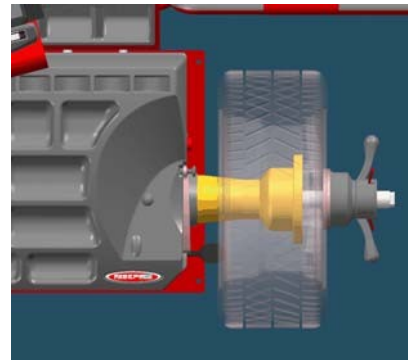

Fig. 48

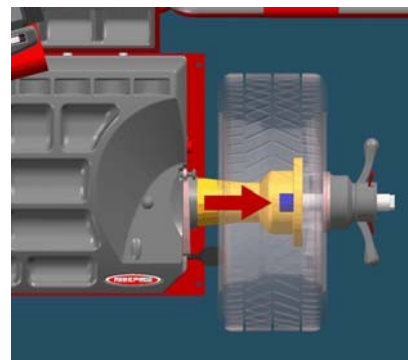

Fig. 49



**NOTE** *Technical calibration is only available to qualified personnel.*

#### 4.2 How to control the calibration of the wheel balancer and position the weight- s (USER)



Fig. 50

Switch on the wheel balancer.

Select **SET UP > CALIBRATION > SET/OK > CHECK CALIBRATION > SET/OK.**

Place a wheel on the shaft and press **<START>** (Fig. 47).

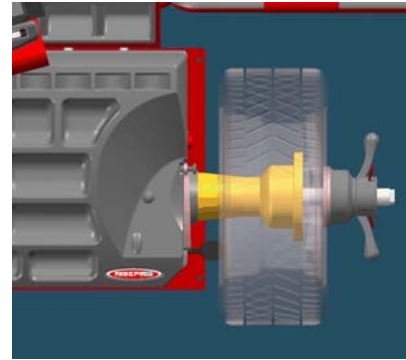

Fig. 51

Place the calibration weight (Fig. 48) and press **<SET/OK>**.

Close the wheel guard or press **<START>**.

At the end of the spin, **160-0** will appear on the display (tolerance allowed is  $\pm 10$ ).

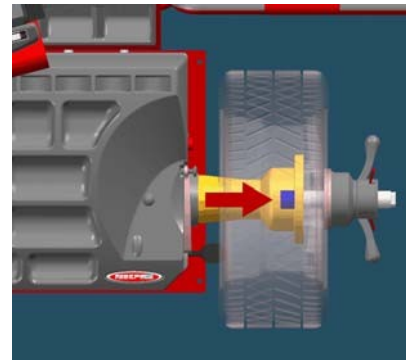

Fig. 52

Set the weight to the 6 o'clock position: the weight indicators on the inside must both be green.

If not, press **<6h>**.

Set the weight to 6 o'clock and press **<SET OK>**.

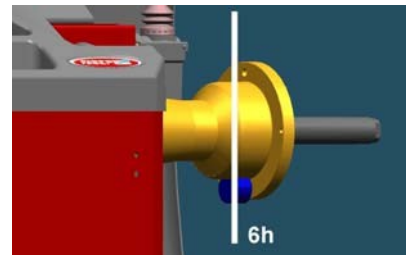

Fig. 53



**NOTE** *Technical calibration is only available to qualified personnel.*

## 5 Calibration ALU- SE

Switch on the wheel balancer.

**MAIN MENU > MENU > RESET > CALIB > ALU-SE  
CALIBRATION > SET/OK**

Place the rod in the rest position (Fig. 50) and press **SET/OK**.

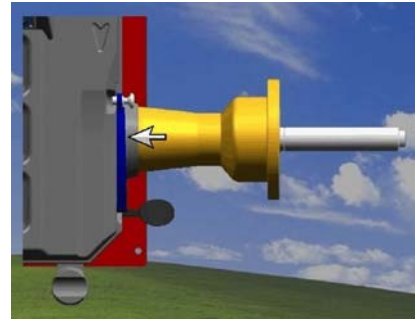

Fig. 54

Place the rod on the flange (fig. 51) and press **SET/OK**.

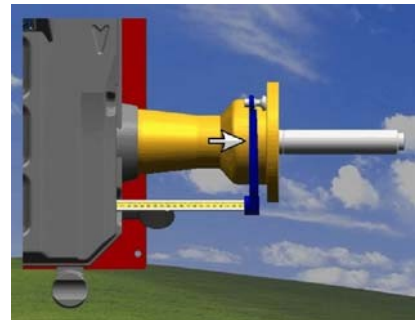

Fig. 55

Select the width of the wheel

Place the rod on the inside of the rim (fig. 52) and press **SET/OK**.

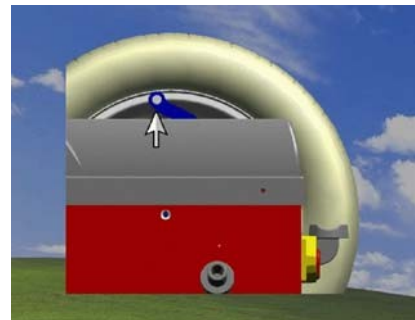

Fig. 56

Press **<ESC>** to return to standard mode.

## 6 Calibration SME

Switch on the wheel balancer.

**MAIN MENU > MENU > RESET > CALIB > SME  
CALIBRATION > SET/OK**

Place the rod in the rest position (Fig. 53) and press **SET/OK**.

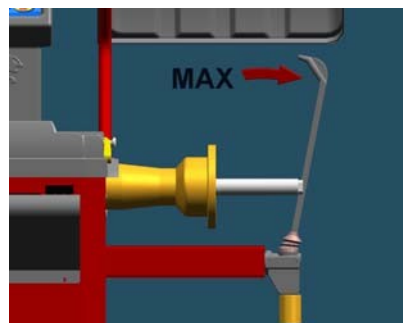

Fig. 57

Insert the rod (fig. 54) and press **SET/OK**.

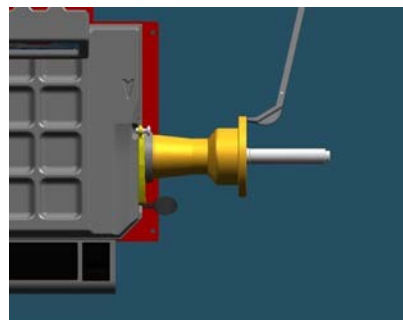

Fig. 58

Press **<ESC>** to return to standard operation.

## 7 MEASUREMENT AND CORRECTION OF UMBALANCE

### 7.1 Placing the wheel rim on the wheel balancer

7.1.1 Select the cone or flange suitable for the wheel to be balanced. Specific mounting instructions are supplied with each flange



**NOTE:** *the process of centring and tightening the wheel onto the flanges is of fundamental importance for correct balancing. Good results depend on these procedures being carried out correctly. Ensure that the connection surfaces are thoroughly cleaned before carrying out any work.*



**CAUTION:** *Always ensure that the flanges are correctly secured to the motor shaft and that the wheel is correctly secured to the flange being used.*

### 7.2 Input of Rim Dimensions (external measuring system- -version) for V65x, V64x, V55x-D (automatic input of all data)



**NOTE:** The AUTOSELECT function allows you to choose the automatic selection of the balancing system (Dynamic, ALU-S1, ALU-S2)

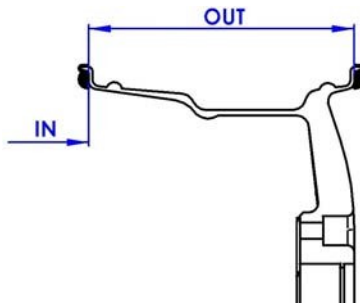

#### MAIN MENU

Enter the distance (Fig. 56).

Enter the width (Fig. 57).

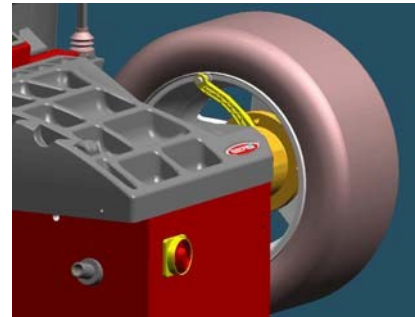

Fig. 60: Distance

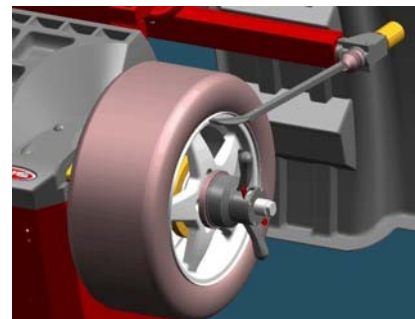
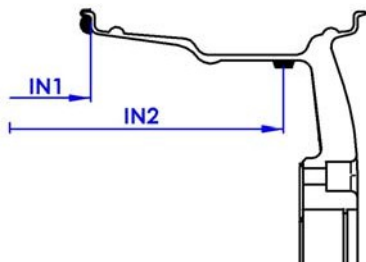

Fig. 61: Width

### 7.3 Input of Rim Dimensions (ALU-SE or LASER- -version)



**CAUTION:** *The laser installed on the wheel balancer is Class 2, so no special protective measures are required. However, it is recommended to avoid continuous direct viewing of the beam.*



#### MAIN MENU > INPUT

Press **ALU MODE** until the required weight position is displayed on the screen (Fig. 58).

Enter the distance (IN1).

Enter the distance (IN2).

Fig. 62

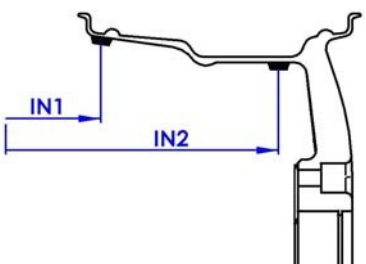

Press **ALU MODE** until the required weight position is displayed on the screen (Fig. 59).

Enter the distance (IN1).

Enter the distance (IN2).

Fig. 63

### 7.4 Detecting and correcting wheel im

7.4.1 After setting the wheel dimensions, press **<START>** or close the safety cover to spin the wheel and start the measurement run.



**CAUTION:** *The wheel starts automatically when the safety cover is closed.*

7.4.2 At the end of the spin, the wheel will brake automatically and the display will show the weight position and the weight required to correct the wheel's imbalance.

7.4.3 Apply the weights (Fig. 60, Fig. 61). If the imbalance shown is 0, press **<FINE>** to display the residual imbalance.



Fig. 64



Fig. 65

### 7.5 How to apply the weight using the ALU-SE applicator



Fig. 66

Place the weight as shown in figure 63.

Turn the wheel until you reach the weight application position (fig. 62).

Move the rod until it reaches the weight application position.

Apply the weight (fig. 64).

Repeat the procedure for the other side.

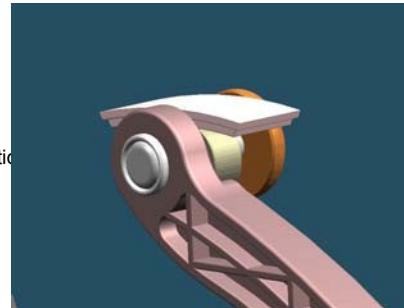

Fig. 67

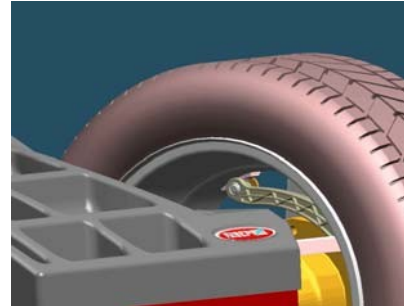

Fig. 68

### 7.6 How to apply the weight using LASER



Fig. 69

Turn the wheel until the position weight indicators on one side are both green (fig. 65).

The laser beam will appear to indicate the point where the weight should be applied (fig. 66).

Apply the weight to the laser dot. Repeat the procedure for the other side.

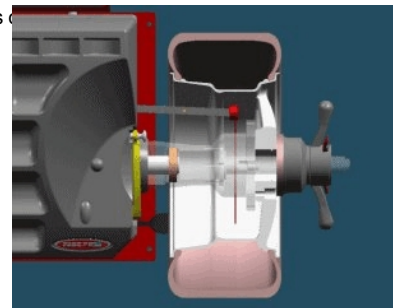

Fig. 70

### 7.7 How to use the SPLIT s Programme

After the measurement, spin

Press **<SPLIT>** to select the programme.

Turn the dial until the first mark (green position) is at 12 o'clock. Press **<SET/OK>** to confirm.

Turn the wheel until the second spoke (red position) is at 12 o'clock.

Press **<SET/OK>** to confirm the red position.

Balance the wheel by applying weights to the green and red positions.

## 8 HOW TO OPTIMISE THE UNBALANCE OF THE WHEEL

### 8.1.1 MAIN MENU > OPTIMISE

Measure the imbalance of the rim only (fig. 67).

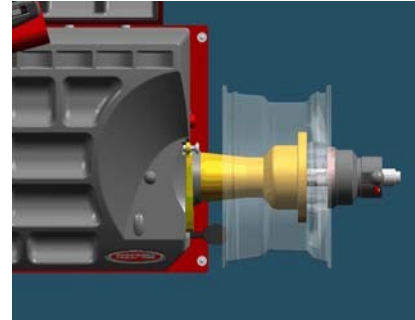

Fig. 71 first spin, rim only

Fit the tyre onto the rim and mount the wheel onto the shaft (fig. 68).

Spin the wheel

Select the optimisation option and follow the video instructions.

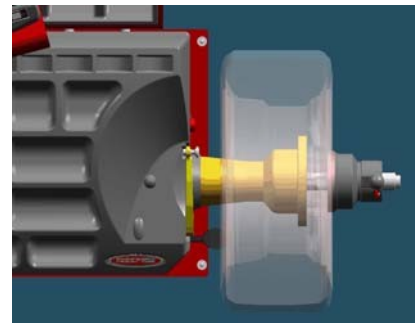

Fig. 72 second spin, complete wheel



**WARNING:** *When balancing with flanges, ensure the accessories are fitted to the rim throughout the entire process.*



**NOTE:** *Optimisation selection: the green option is the one recommended by the machine. The user may also choose one of the others.*

## **9 SPECIAL FUNCTIONS**

### **9.1 Language selection**

- 9.1.1 MAIN MENU > SET UP > USER SET UP > LANGUAGE > SET OK >.
- 9.1.2 Select the language and press SET OK.

### **9.2 Setup**

- 9.2.1 MAIN MENU > SET UP > USER SET UP.
- 9.2.2 Select the item and press SET OK.

**APPENDIX**

**A: Technical data**

<b>Power requirements</b>	400W	
<b>Balancing speed</b>	98 rpm	
<b>Measuring time</b>	4–15 s	
<b>Accuracy</b>	±1 gram (±1/28 ounce)	
<b>Wheel dimensions</b>	<b>Diameter Rim diameter</b>	8" (200 mm) – 26" (650 mm)
	<b>Rim width (with wheel guard)</b>	max 16" (415 mm)
	<b>Wheel weight</b>	max 90 kg (198 lbs)

**Wheel balancer dimensions**

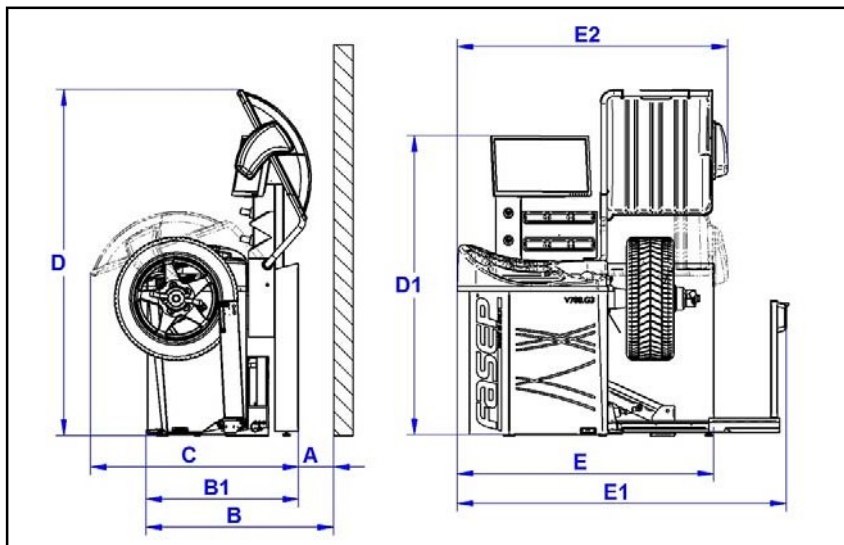

Dimensioni V788.G3	
A	300
B	1080
B1	780
C	1070
D	1770
D1	1530
E	1310
E1	1680
E2	1380
Dim Imballo	145x115x190 (cm)
Peso Lordo	250 kg
Peso netto	210 Kg

**Fig. 73:** Dimensions

## **B: Environmental Data, Safety Features and Requirements**

### **Environmental Data**

#### *[Operating conditions]*

This unit is designed for indoor use only.

Temperature: 0 to 45°C

Relative Humidity: 5 to 80% at 40°

#### *[Storage conditions]*

This package is intended for indoor storage

only. Temperature: -25°C to 70°C

Relative humidity: 5% to 95% at 40°C

### **Safety Features**

1. The balance weights holder may be removed for servicing. It is secured to the machine body with screws so that it can only be removed intentionally. Removal of this protection is therefore restricted to authorised service engineers.
2. The Control Panel may be removed for servicing. It is secured to the machine body with screws so that it can only be removed intentionally. Removal of this protection is therefore restricted to Authorised Service Engineers.



**CAUTION:** *The safety cover is required at all times when using the motorcycle adapter.*

**WARNING** *FASEP 2000 srl shall not be liable for any inconvenience, breakdowns or accidents caused directly or indirectly by unauthorised servicing. Servicing of any parts by unauthorised engineers will void the warranty and any rights of the unit owner.*



**NOTE:** *As this unit operates at speeds below 100 rpm, a safety guard is not required. However, a safety guard is recommended when balancing wheels with a diameter greater than 20".*

### **General Safety Requirements**

#### *[before using/servicing this unit]*

1. Please read this instruction sheet and the entire user manual before operating or servicing the wheel balancer.
2. Ensure that the electrical power supply complies with the requirements shown on the nameplate (see also the model identification chart for reference).
3. Ensure the unit is in a stable position.

#### *[when using the unit]*

4. Protect the power cable leading to the unit from damage.
5. When the work area is being cleaned, ensure the unit is adequately protected.
6. Remove all stones and mud lodged in the tyre treads before balancing the wheel.
7. Do not touch the spinning wheel. Always use the safety guard for protection.
8. Ensure that the counterweights are securely attached before checking for residual imbalance. *[when servicing the unit]*
9. Ensure that power sources are disconnected before carrying out any work on the unit.
10. Servicing of the PCB, electrical and mechanical parts should only be carried out by an Authorised FASEP 2000 Service Centre.

**C: Errors and malfunctions detected by the computer**  
Errors may apply to certain models only.

**ERR 1:** Shaft does not rotate

**ERR 2:** Rotation direction is incorrect

**ERR 3:** Rotation speed is not ready

**ERR 4:** Rotation speed is incorrect (too low or too high)

**ERR 5:** Position sensor or position disc failure **ERR 6:**  
Safety cover is open

**ERR 7:** Measurement cycle was interrupted

**ERR 8:** Calibration weight was not inserted. **ERR**

**9:** Activation code incorrect

**ERR 10:** Overflow in calculations **ERR**

**11:** Serial number is incorrect **ERR 12:**

Serial number not entered **ERR 13:**

Reserved

**ERR 14:** Incorrect password

**ERR 15:** E<sup>2</sup>PROM error

**ERR 16:** Calibration memory error **ERR**

**17:** Rod in incorrect position **ERR 18:**

Excessive weight detected **ERR 19:**

Reserved

**ERR 20:** Reserved

**ERR 21:** Error in data input

**ERR 22:** Brake error

**ERR 23:** Substance change due to shaking

**ERR 24:** Reserved

**ERR 25:** Reserved

**ERR 26:** Reserved

**ERR 27:** Insufficient pressure

**D: How to safely remove the battery from the product .**



**Disposal of waste batteries (applicable in the European Union and other European countries with separate collection systems)**

This symbol on the battery or on the packaging indicates that the battery supplied with this product must not be treated as household waste. By ensuring these batteries are disposed of correctly, you will help prevent potential negative consequences for the environment and human health that could otherwise result from the improper disposal of the battery. Recycling the materials will help conserve natural resources.

In the case of products that, for safety, performance or data integrity reasons, require a permanent connection to a built-in battery, this battery should only be replaced by qualified service personnel. To ensure that the battery is disposed of properly, hand the product over to the relevant collection point for the recycling of electrical and electronic equipment at the end of its life.

Hand the battery over to the relevant collection point for the recycling of waste batteries.

For more detailed information about recycling this product or battery, please contact your local council or your household waste collection service.

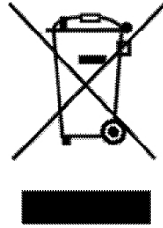

#### User information

**Pursuant to Article 13 of Legislative Decree No. 151 of 25 July 2005, "Implementation of Directives 2002/95/EC, 2002/96/EC and 2003/108/EC on the restriction of the use of certain hazardous substances in electrical and electronic equipment and on waste management"**

The crossed-out wheeled bin symbol shown on the equipment or its packaging indicates that the product must be collected separately from other waste at the end of its useful life.

The separate collection of this end-of-life equipment is organised and managed by the manufacturer. Users wishing to dispose of this equipment must therefore contact the manufacturer and follow the system they have put in place to facilitate the separate collection of end-of-life equipment.

Proper separate collection, followed by the recycling, treatment and environmentally sound disposal of the end-of-life equipment, helps to prevent potential negative effects on the environment and human health and promotes the reuse and/or recycling of the materials from which the equipment is made.

Illegal disposal of the product by the holder will result in the imposition of the administrative penalties provided for under current legislation.

#### English

##### **Disposal of Waste Electrical & Electronic Equipment (Applicable in the European Union only)**

The symbol (crossed-out wheeled bin) on your product indicates that the product must not be mixed with or disposed of as part of your household waste at the end of its useful life.

This product must be handed over to your local community waste collection point for recycling.

For further information, please contact your national waste disposal authority. Improper waste management may have a negative impact on the environment and human health due to the presence of potentially hazardous substances. By cooperating in the correct disposal of this product, you contribute to its reuse, recycling and recovery, thereby helping to protect our environment.

For further information, please contact your dealer or distributor in your country. This product must not be mixed with or disposed of as commercial waste.

#### French

##### **Disposal of electrical and electronic equipment at the end of its life (Applicable in European Union countries only)**

This symbol (crossed-out wheeled bin) on the product indicates that, at the end of its life, this product must not be disposed of with household waste.

It must be taken to an appropriate collection point for the recycling of electrical and electronic equipment.

For further information, please contact your local household waste collection service. This product contains potentially hazardous substances that may have harmful effects on the environment and human health. By ensuring this product is disposed of correctly, you will help to ensure its proper treatment, recovery and recycling, and protect the environment.

For further information, please contact your local dealer or distributor. This product must not be disposed of with general waste.

#### Spanish

##### **Waste Electrical and Electronic Equipment Directive (Applicable only to the European Union)**

Products marked with this symbol (crossed-out wheeled bin) must not be disposed of as household waste at the end of their useful life.

This product must be taken to a local collection point for recovery and recycling.

For further information, please contact your local council's Waste Management Department. Improper waste management poses risks to human health and the environment. By reusing, recycling materials or finding other ways to recover value from these products, you are making a significant contribution to protecting our environment.

For further information, please contact the authorised dealer or distributor in your country. This product must not be mixed with or disposed of as part of general waste.

#### Deutsch

##### **Disposal of electrical and electronic equipment (Applicable only in European Union countries)**

This symbol (a crossed-out wheeled bin) on the product indicates that old appliances etc. must not be disposed of as normal household waste, but must be taken to a designated collection point for recycling.

For further information, please contact your local waste disposal authorities. Improper disposal may result in adverse effects on the environment and human health due to potentially hazardous substances. By cooperating to ensure proper disposal, you are promoting the reuse, recycling and recovery of materials and contributing to environmental protection.

For further information, please contact your dealer or the relevant sales department. The product must not be disposed of with normal commercial waste.

---

**CE Declaration of Conformity EU  
Declaration of Conformity  
Dèclaration CE de conformité EU  
Konformitätserklärung  
Declaración de Conformidad CE  
Deklaracja Zgodności CE**

---

**FASEP 2000 Ltd  
Via Faentina 96,  
50032 Ronta (Fi), Italy.**

- declares, under its sole responsibility, that the product indicated below complies with the directives and standards indicated:
- declares, under its own responsibility, that the equipment indicated below complies with the following standards and directives:
- declares, under its own responsibility, that the equipment indicated below complies with the following standards and directives:
- declares, under its sole responsibility, that the product listed below complies with the standards and directives indicated:
- declares, under full responsibility, that the equipment listed below complies with the following standards and directives:

**Type of product / Type of equipment / Typ urządzenia:** wheel balancers / wheel balancers / wyważarka do kół  
**Model, Serial No. / Model, Serial No. / Model, serial number:** see nameplate / see badge / see label

Applicable Directives / Applied CE Directives / Stosowane Dyrektywy

Machinery Directive / Directive Machines / Dyrektywa maszynowa: **2006/42/EC**

Low Voltage Directive / Low Voltage Directive / Low Voltage Directive: **2006/95/EC - 2014/35/EU**

Electromagnetic Compatibility Directive / Electromagnetic Compatibility Directive /

Electromagnetic Compatibility Directive: **2004/108/EC - 2014/30/EU**

Applied Harmonised Standards / Stosowane normy zharmonizowane

**UNI EN ISO 12100-1:2005, UNI EN ISO 12100-2:2005, CEI EN 60204-1:2006, EN 61000-6-3:2001, EN 61000-6-1:2001, UNI EN ISO 14121-1:2007**

Ronta, Florence

Date \_\_\_\_\_



---

**FASEP 2000 srl**  
Fulvio Boni, Chairman

Person authorised to compile the Technical File:  
Entity responsible for providing the technical documentation: Fasep 2000  
srl, Via Faentina 96 - Ronta, 50032 Borgo San Lorenzo (Fi)