



www.fasep.it

User's MANUAL

V585.2.U

VIDEOTRONIC V585.2.U USER'S MANUAL



For any information, please contact:

e-mail:

FASEP 2000 srl
Via Faentina 96
50032 Ronta (Fi) Italy
Tel. #39 055 8403126
Fax #39 055 2691906

www.fasep.it
export@fasep.it

WARNING

.This document contains information which is the property of FASEP 2000 rl and all rights are reserved. This manual shall not be photocopied or reproduced in any way without the prior written consent of FASEP 2000 srl.

.FASEP 2000 srl reserves the right to revise products firmware, software or documentation without obligation to notify any person or organization. The information contained in this document is subject to change without warning.

.Prior of the installation of the unit described in this manual, user should read this manual carefully to be instructed properly on installation, use and maintenance of the unit.

.Failing to read this manual and operate accordingly may cause damage to the user or the unit.





.FASEP 2000 srl shall not be responsible for inconvenience, breakdown, accidents due to uncomplete knowledge of this manual or uncomplete application of raccomandations described in this manual.

.FASP 2000 srl shall not be responsible for inconvenience, breakdown, accidents due to unauthorized modifications of the unit, use of non-original or unauthorized accessories (see Accessories listing in this manual for a list of original accessories available for this model).

.FASEP 2000 srl shall not be responsible for any inconvenience, breakdown, accidents caused directly or indirectly by not qualified service. Service to any parts by not qualified persons will void warranty and will void any right of the owner of the unit.

SYMBOLS AND CONVENTIONS

To speed the retrieval of main information and make easy to understand the instructions, this manual uses the following typing conventions:

<NAME OF THE PUSH BUTTON>	Used to indicate name of push-buttons on the control panel.
DISPLAY	Used to indicate text or number visible on the displays on the control panel.
 ADVICES	Contain useful advices or solutions, evidenced with respect to the rest of the text.
 NOTE	Notes contain important information, evidenced to the rest of the text.
 WARNING	Warning messages appears corresponding to procedures that, if not properly observed, may lead to loose of data or cause damage to the unit.
 CAUTION	Caution messages appears corresponding to procedures that, if not properly observed, may cause injuries to the user.

ORIGINAL INSTRUCTIONS

TABLE OF CONTENTS

WARNING	ii
SYMBOLS AND CONVENTIONS	ii
1 PRESENTATION	1-1
1.0 Intended Use	1-1
1.1 Definitions	1-1
2 INSTALLATION	2-1
2.1 Moving the unit	2-1
2.2 Assembling the unit	2-1
2.3 Installation	2-1
2.4 Electrical Hookup	2-1
2.5 Compressed air Hookup (PL models only)	2-1
3 USE OF CONTROL PANEL	2-2
3.1 Meaning of the icons on the screen	2-2
4 CALIBRATION OF WHEEL BALANCER	2-5
4.1 How to calibrate the wheel balancer (USER)	2-5
4.2 How to control the calibration of wheel balancer and position weight (USER)	2-6
5 Calibration ALU-SE	3-5
6 Calibration SONAR	3-6
7 MEASUREMENT AND CORRECTION OF UMBALANCE	3-7
7.1 Placing the wheel rim on the wheel balancer	3-7
7.2 Input of Rim Dimensions (Sonar system version)	3-7
7.3 Input of Rim Dimensions (ALU-SE or LASER version)	3-8
7.4 Detecting and correcting umbalance	3-8
7.5 How to apply the weight using ALU-SE applicator	3-9
7.6 How to apply the weight using LASER	3-9
7.7 How to use SPLIT Program	3-9
8 HOW TO OPTIMIZE UNBALANCE OF THE WHEEL	4-1
9 SPECIAL FUNCTIONS	5-1
9.1 Language selection	5-1
9.2 Setup	5-1
APPENDIX	A-2
A: Technical data	A-2
B: Environmental Data, Safety Features and Requirements	B-1
C: Errors and Malfunctions recognized by the Computer	B-2

1 PRESENTATION

1.0 Intended Use

This unit is designed to measure and correct static and dynamic unbalance of vehicle wheel, the dimension and weight of which are within the working range of the machine (see "Technical Data" appendix for reference)

This unit is meant for a professional use. Operator shall be properly trained before use. Training Course is not included in the price of the unit and must be purchased separately.

This unit is designed for indoor use only (see "Environmental Data" appendix for reference).



CAUTION:

This unit is designed to spin vehicle wheels only, within the range of dimensions and weight approved (see "Technical Data" appendix for reference). Special adaptors suit this purpose. Do not attempt to use the machine to spin anything else. Unproper locking may cause the part being spinned to be ejected, causing damage to the unit itself, the operator or anything in the in the neighborhood.

1.1 Definitions

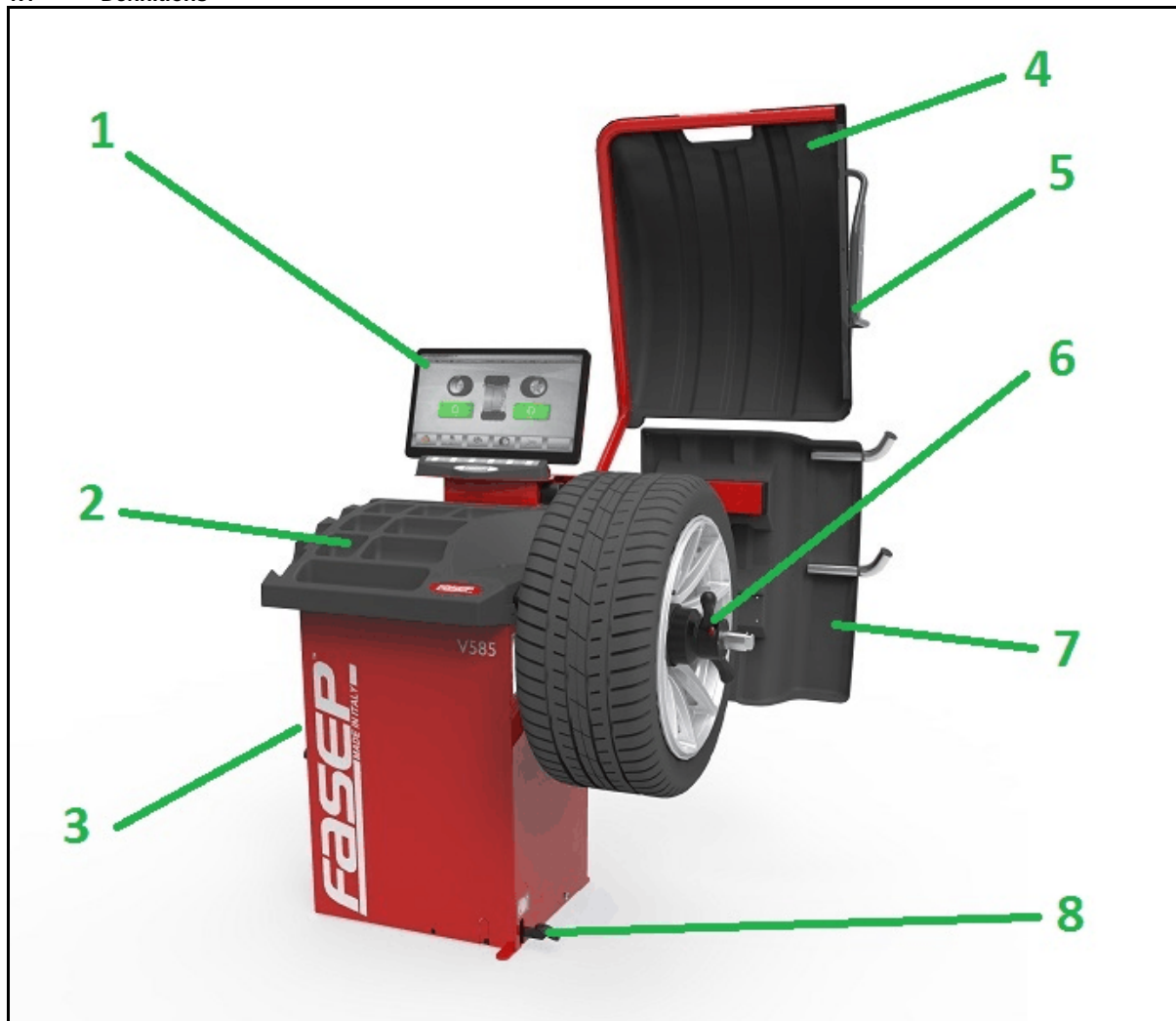

1. Monitor
2. Weights and tools trays
3. Side flange-holders
4. Wheel guard

5. 3D Sonar input (optional)
6. Quick lock + HD shaft
7. Lower wheel guard (optional)
8. Foot-pedal

2 INSTALLATION

2.1 Moving the unit



WARNING When the unit has to be moved: never lift balancer by motor shaft or by neighborhood of it.

2.2 Assembling the unit

For ease of transportation, the wheel balancer might be disassembled into units. If necessary, assembling instruction are provided within each package..

2.3 Installation

The wheel balancer must be installed on a firm and level ground.



NOTE: the machine must be secured to the floor. Using four holes in the base and anchor bolts provided

2.4 Electrical Hookup



CAUTION: Failure to follow these instructions can results in damage to unit or create an electrical hazard and will void warranty..

2.4.1 Electrical hookup is to be provided by a qualified electrician.

2.4.2 A fusible wall-mounted switchbox is required at the installation site. This switch should provide on-off control and overload protection for your wheel balancer only. The switchbox should be fused with time-delay fuse(s) in accordance with the power rating specified on your wheel balancer.

2.4.3 Electrical connection of the machine should be by plug connectors.

2.4.4 The balancer must be effectively connected to ground. The electric cord is regularly provided with a ground terminal.

2.4.5 Make sure that Power Rate Specifications for your wheel balancer (refer to nameplate on the wheel balancer) comply with those provided by the external power source.



CAUTION After electrical hookup has been performed unit is ready to operate. Always observe pertinent safety precautions when operating the unit (see Appendix tables for an overview of relevant Safety requirement).

2.5 Compressed air Hookup (PL models only)



CAUTION Failure to follow these instructions can result in damage to unit or create a hazard and will void warranty.

1. Compressed Air hookup is to be provided by a qualified technician, under the local safety requirements, in line with relevant national standards and regulations. All fitting and hoses must conform to local codes.
2. A wall-mounted lubricator and water-separator is required at the installation site.
3. Compressed Air circuit to the balancer shall be regulated to a pressure of min 6,5atm - max 10atm. Overpressure could compromise cylinder operation.

2.5.1 CONNECT TO AIR SUPPLY:

The machine is fitted with a universal connector and therefore no other special or additional fitting is required. Push all the way onto the connector a high pressure rubber air-hose and secure it.

2.6 Power

Plug the wheel balancer into a 220V socket. To switch on the wheel balancer press the red button (power). To swich off the wheel balancer press the red button (power).

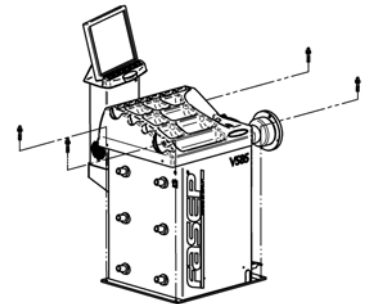
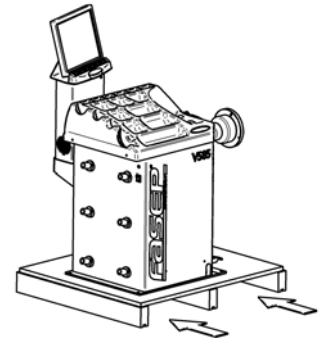

3 USE OF CONTROL PANEL



Fig. 6 Panel V585

3.1 Meaning of the icons on the screen



Fig. 7

Select balancing mode

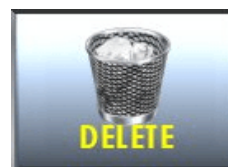

Fig. 10

Delete last character in input activation code



Fig. 8

APS Function



Fig. 11

Change selection



Fig. 9

Calibration

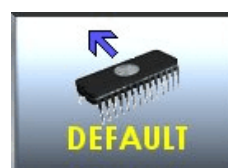

Fig. 12

Set default values



Fig. 13

Diagnostic



Fig. 20

Laser calibration



Fig. 14

Key down

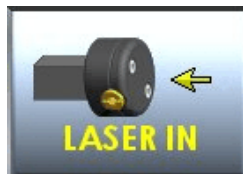

Fig. 21

Put in the rod laser in rest position



Fig. 15

Position calibration



Fig. 22

Start laser



Fig. 16

Go to previous page



Fig. 23

Extract fully rod laser



Fig. 17

Fine resolution



Fig. 24

Manul input measures



Fig. 18

Access to Information center

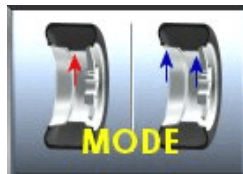

Fig. 25

Set Dynamic/Static



Fig. 19

Access to page measures



Fig. 26

Mode moto



Fig. 27

Key SET/OK



Fig. 34

Set measures



Fig. 28

Double operator



Fig. 35

Go to setup menu



Fig. 29

Optimize



Fig. 36

Skip current operation



Fig. 30

Restart software



Fig. 37

Split function



Fig. 31

Reset partial statistics



Fig. 38

Stop turning wheel



Fig. 32

Reset variation in page Sensor



Fig. 39

Key up



Fig. 33

Save



Fig. 40

View menu and selection (UP/DOWN)

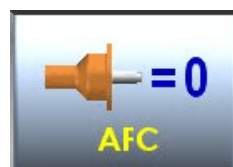

Fig. 41

Automatic flange calibration

4 CALIBRATION OF WHEEL BALANCER

4.1 How to calibrate the wheel balancer (USER)



NOTE: *the following symptoms indicate need for calibration::*

a) *check calibration program fails.*

b) *constant low or high weight readings.*

c) *indicated point of unbalance constantly wrong*

d) *more than 2 spins required to balance wheels repeatedly.*



Fig. 42

Switch on the wheel balancer.

Select **SET UP > CALIBRATION > SET/OK > CALIBRATION > SET/OK.**

Spin with no wheel on shaft (Fig. 42)

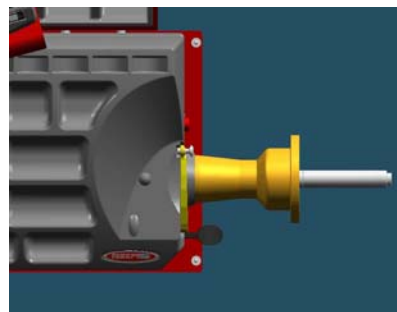

Fig. 43

Close the wheel guard or press **<START>**.

At the end of the spin, put a wheel (Fig. 43) and close the wheel guard or press **<START>**.

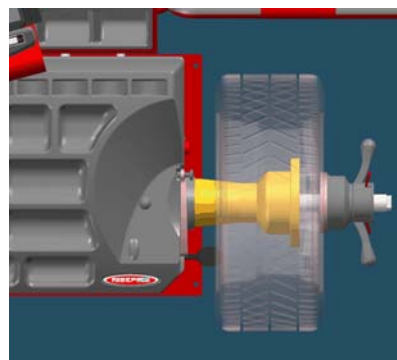

Fig. 44

At the end of the spin, put the calibration weight (Fig. 44) and close the wheel guard or press **<START>**.

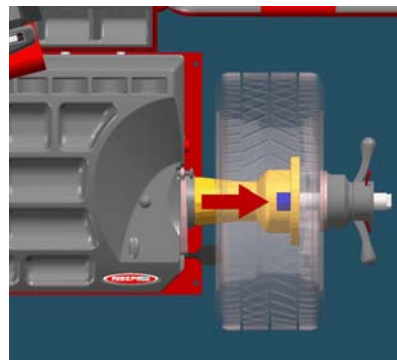

Fig. 45



NOTE *technical calibration is only available for qualified personnel.*

4.2 How to control the calibration of wheel balancer and position weight (USER)



Fig. 46

Switch on the wheel balancer.

Select **SET UP > CALIBRATION > SET/OK > CHECK CALIBRATION > SET/OK.**

Put a wheel on the shaft and press **<START>** (Fig.46).

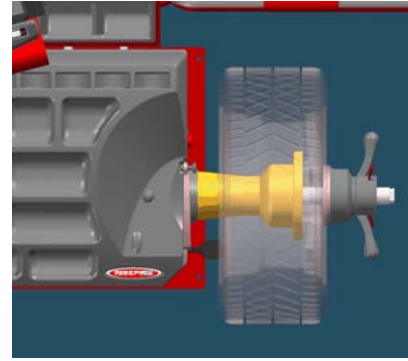

Fig. 47

Put the calibration weight (Fig.47) and press **<SET/OK>**.

Close the wheel guard or press **<START>**.

At the end of the spin, **160-0** will show on the video (tolerance allowed is ± 10).

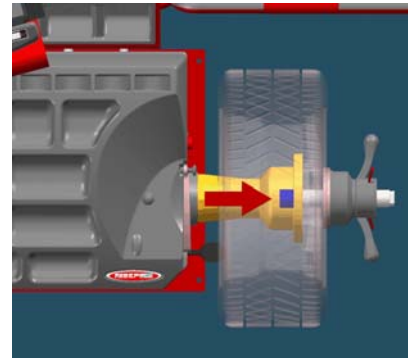

Fig. 48

Put the weight at 6h o'clock: the weight indicators of internal side must be both green.

If not, press **<6h>**.

Put the weight at 6h o'clock and press **<SET OK>**.

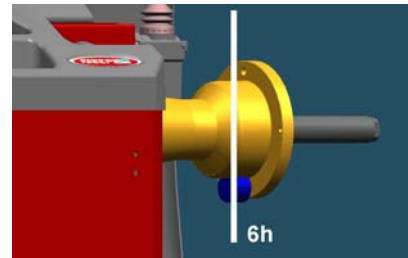

Fig. 49



NOTE *technical calibration is only available for qualified personnel.*

5 Calibration ALU-SE

Switch on the wheel balancer.

**MAIN MENU > MENU > RESET > SET UP > CALIBRATION
> ALU-SE CALIBRATION > SET/OK** (fig.49).

Put the rod on rest position (fig.49) and press **SET/ OK**.

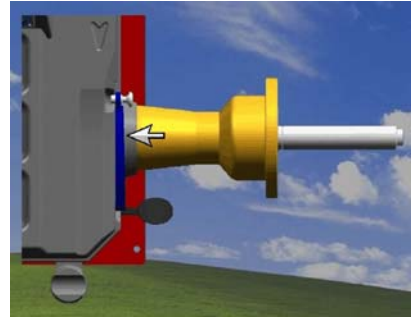

Fig. 50

Put the rod on the flange (fig.50) and press **SET/ OK**.

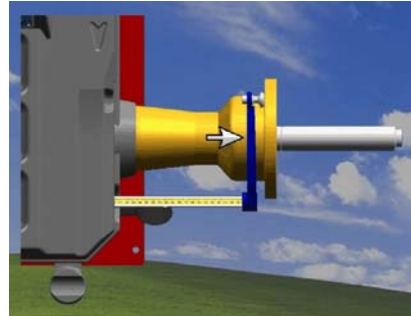

Fig. 51

Select width of wheel

Put the rod on internal side of the rim (fig.51) and press **SET/OK**.

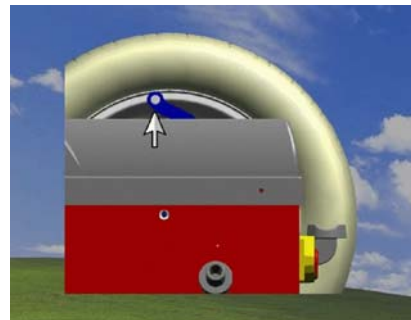

Fig. 52

Press **<ESC>** to go back to standard use.

6 Calibration SONAR



NOTE *Sonar calibration is only available for qualified personnel.*

7 MEASUREMENT AND CORRECTION OF UMBALANCE

7.1 Placing the wheel rim on the wheel balancer

7.1.1 Select the cone or flange suitable for the wheel to be balanced. Specific mounting instructions are delivered with each flange



NOTE: *the operation of centering and tightening of the wheel on the flanges is of basic importance for correct balancing. Good results depend on proper performance of these procedures. To accurately clean up the superficial ones of connection before whichever operation.*



CAUTION: *Always make sure flanges are correctly locked on the motor shaft and wheel is correctly locked on the flange being used.*

7.2 Input of Rim Dimensions (Sonar system version) for V65x, V64x, V55x-D (automatic input of all data)



NOTE: AUTOSELECT function allows automatic selection of balancing system (Dynamic, ALU-S1, ALU-S2)

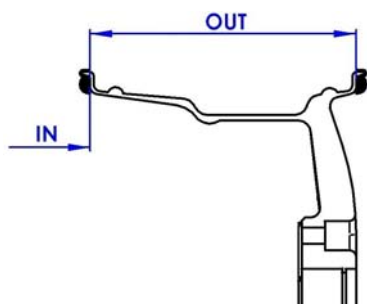

MAIN MENU

Insert the distance (fig.54).

Lower the wheel guard to insert automatically the width (fig.55).

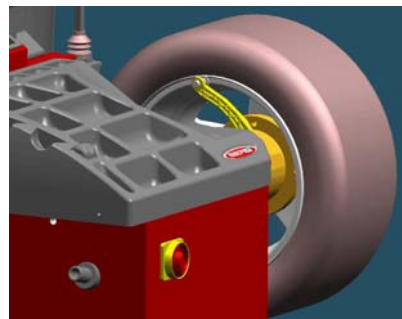

Fig. 54: Distance



Fig. 55: Width

7.3 Input of Rim Dimensions (ALU-SE or LASER version)



CAUTION:

Laser installed on wheel balancer is of class 2, so special protection are not required. It is however recommended to avoid the continuous view of the direct beam.

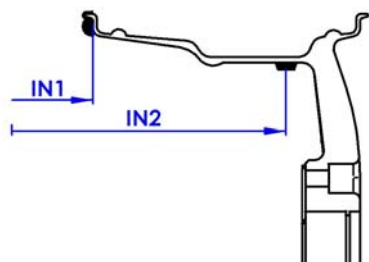

MAIN MENU > INPUT

Press **ALU MODE** until the required position of weight is on the video (fig.56).

Insert the distance (IN1).

Insert the distance (IN2).

Fig. 56

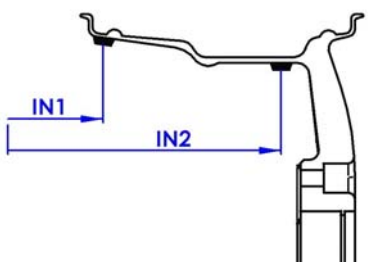

Press **ALU MODE** until the required position of weight is on the video (fig.57).

Insert the distance (IN1).

Insert the distance (IN2).

Fig. 57

7.4 Detecting and correcting unbalance

7.4.1 After setting wheel dimensions, press **<START>** or close the safety cover to spin the wheel and start the measurement run.



CAUTION:

wheel start automatically when safety cover is closed.

7.4.2 At the end of the spin the wheel will brake automatically and the display will show the weight position and weight requirement to correct the wheel's unbalance.

7.4.3 Apply the weights (fig.58, fig.59). If unbalance shown is 0, press **<FINE>** to show residual unbalance.



Fig. 58



Fig. 59

7.5 How to apply the weight using ALU-SE applicator



Fig. 60

Place the weight as in the picture 61.

Turn the wheel until reach the application position of the weight (fig. 60).

Move the rod until reach the application position of the weight.

Apply the weight(fig. 62).

Repeat the procedure for the other side.

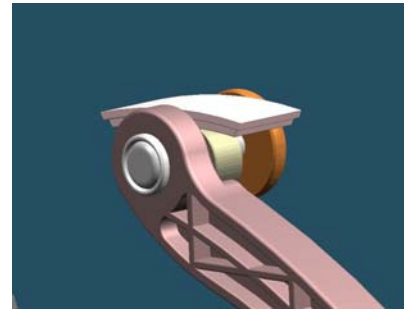

Fig. 61

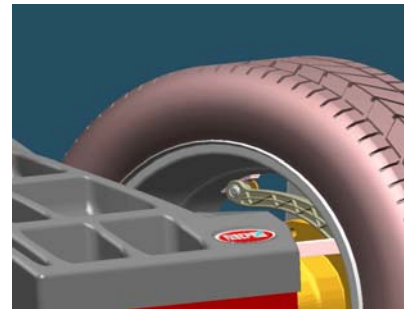

Fig. 62

7.6 How to apply the weight using LASER



Fig. 63

Turn the wheel until the position weight indicators of one side are both green (fig. 63).

The laser come out to show the point of application of the weight (fig. 64).

Apply the weight on the laser dot.

Repeat the procedure for the other side.

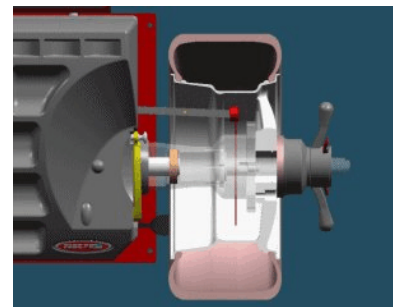

Fig. 64

7.7 How to use SPLIT Program

After the measurement spin

Press **<SPLIT>** to select the program.

Turn the wheel until first spoke (green position) is at 12 o' clock.

Press **<SET/OK>** to confirm.

Turn the wheel until second spoke (red position) is at 12 o' clock

Press **<SET/OK>** to confirm the red position.

Balance the wheel applying weight on green and red positions.

8 HOW TO OPTIMIZE UNBALANCE OF THE WHEEL

8.1.1 MAIN MENU > OPTIMIZE

Measure the unbalance of the rim only (fig. 65).

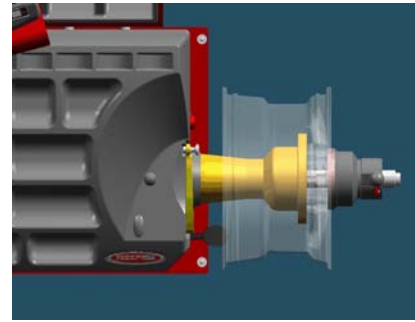

Fig. 65 first spin, rim only

Mount the tire on the rim and put the wheel on the shaft (fig.66).

Spin the wheel

Select the optimization and follow the video instruction.

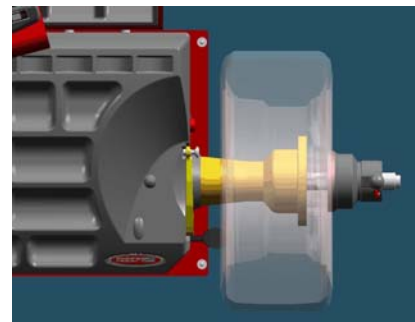

Fig. 66 second spin, complete wheel



WARNING: *Balancing with flanges, put the accessories assembled to the rim during the complete operations.*



NOTE: *Selection of optimization: the green solution is the advised from the machine. The user can be choose also one of the other.*

9 SPECIAL FUNCTIONS

9.1 Language selection

- 9.1.1 MAIN MENU >SET UP > USER SET UP > LANGUAGE > SET OK >.
- 9.1.2 Select the language and press SET OK.

9.2 Setup

- 9.2.1 MAIN MENU >SET UP > USER SET UP .
- 9.2.2 Select item and press SET OK.

APPENDIX

A: Technical data

Power requirement	400W	
Speed Balancing	98RPM	
Measuring time	4-15 s.	
Accuracy	±1grammo (±1/28 once)	
Wheel Dimensions	Diameter Rim diameter	8" (200 mm) - 26" (650 mm)
	Rim Width (with wheel-guard)	max 16" (415mm)
	Wheel Weight	max 90 Kg (198Lbs)

Wheel balancer dimensions

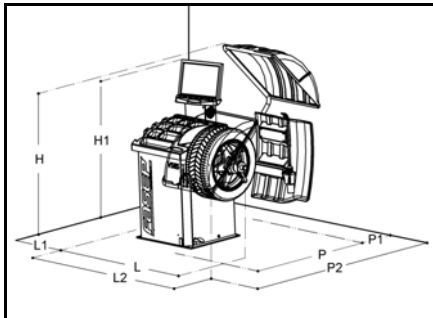

Fig. 67: Measures

	V585
L (mm)	1030
L1 (mm)	500
L2 (mm)	1130
P (mm)	960
P1 (mm)	200
P2 (mm)	1390
H (mm)	1500
H1 (mm)	1270
Peso (kg)	116

B: Environmental Data, Safety Features and Requirements

Environmental Data

[Operating conditions]

This unit is designed for indoor use only.

Temperature: 0 to 45°C

Relative Humidity: 5 to 80% a 40°

[Storage conditions]

Package is designed for indoor storage only.

Temperature: -25° to 70°C

Relative humidity: 5 at 95% to 40°C

Safety Features

1. The Balance Weights Holder may be removed for servicing. It is secured to the machine body through screws so that only voluntarily it may be removed. Removal of this protection is therefore restricted to Authorized Service Engineers.
2. The Control Panel may be removed for servicing. It is secured to the machine body through screws so that only voluntarily it may be removed. Removal of this protection is therefore restricted to Authorized Service Engineers.



CAUTION: *The safety cover is anyway required when using the motorcycle adapter.*



WARNING *FASEP 2000 srl shall not be responsible for any inconvenience, breakdown, accidents caused directly or indirectly by unauthorized service. Service to any parts by unauthorized engineers will void warranty and will any right of the owner of the unit..*



NOTE: *As this unit runs at speed below 100rpm, a safety cover is not required. However a safety cover is recommended when balancing wheels with diameter bigger than 20".*

General Safety Requirement

[before using/servicing this unit]

1. Read this instruction sheet and the whole user's manual before operating or servicing the wheel balancer.
2. Make sure electrical power source conforms to requirements shown on nameplate (see also model identification chart for reference).
3. Make sure the unit has a stable position.
[when using the unit]
4. Protect power leading to the unit from damage.
5. When work area is being washed, make sure unit is adequately protected.
6. Remove all stones and mud lodged in tire treads before balancing the wheel.
7. Do not touch spinning wheel. Always use Safety Safety cover to be protected.
8. Make sure counterweights are securely attached before checking residual unbalance.
[when servicing the unit]
9. Make sure power sources are disconnected before service on the unit is performed.
10. Service to PCB, electrical and mechanical parts should be done only by an Authorized FASEP 2000 Service Center.

C: Errors and Malfunctions recognized by the Computer

Errors may apply to some model only.

- | | |
|--|--|
| ERR 1: Shaft does not rotate | ERR 16: Calibration memory error |
| ERR 2: Rotation Direction is wrong | ERR 17: Rod in uncorrect position |
| ERR 3: Rotation speed is not ready | ERR 18: Excessive weight detected |
| ERR 4: Rotation speed is wrong (too low or too high) | ERR 19: Reserved |
| ERR 5: Position Sensor or Position Disk failure | ERR 20: Reserved |
| ERR 6: Safety Safety cover is open | ERR 21: Error in inputting data |
| ERR 7: Measuring cycle was interrupted | ERR 22: Brake error |
| ERR 8: Calibration weight was not inserted. | ERR 23: Substance change due to shakes |
| ERR 9: Activation code not correct | ERR 24: Reserved |
| ERR 10: Overflow in calculations | ERR 25: Reserved |
| ERR 11: Serial number is wrong | ERR 26: Reserved |
| ERR 12: Serial number not inserted | ERR 27: Insufficient pressure |
| ERR 13: Reserved | |
| ERR 14: Uncorrect password | |
| ERR 15: E ² prom error | |

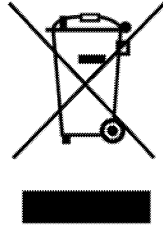

Informazione agli utenti

ai sensi dell'art. 13 del Decreto legislativo 25 Luglio 2005, n. 151 "Attuazione delle Direttive 2002/95/CE, 2002/96/CE e 2003/108/CE, relative alla riduzione dell'uso di sostanze pericolose nelle apparecchiature elettriche ed elettroniche, nonché allo smaltimento dei rifiuti"

Il simbolo del cassonetto barrato riportato sull'apparecchiatura o sulla sua confezione indica che il prodotto alla fine della propria vita utile deve essere raccolto separatamente dagli altri rifiuti.

La raccolta differenziata della presente apparecchiatura giunta a fine vita è organizzata e gestita dal produttore. L'utente che vorrà disfarsi della presente apparecchiatura dovrà quindi contattare il produttore e seguire il sistema che questo ha adottato per consentire la raccolta separata dell'apparecchiatura giunta a fine vita.

L'adeguata raccolta differenziata per l'avvio successivo dell'apparecchiatura dismessa al riciclaggio, al trattamento e allo smaltimento ambientalmente compatibile contribuisce ad evitare possibili effetti negativi sull'ambiente e sulla salute e favorisce il reimpiego e/o riciclo dei materiali di cui è composta l'apparecchiatura.

Lo smaltimento abusivo del prodotto da parte del detentore comporta l'applicazione delle sanzioni amministrative previste dalla normativa vigente.

English

Disposal of Waste Electrical & Electronic Equipment (Applicable in the European Union only)

The symbol (crossed out wheeled-bin) on your product indicates that the product shall not be mixed or disposed with your household waste, at their end of use.

This product shall be handed over to your local community waste collection point for the recycling of the product.

For more information, please contact your Government Waste-Disposal department in your country. Inappropriate waste handling could possibly have a negative effect on the environment and human health due to potential hazardous substances. With your cooperation in the correct disposal of this product, you contribute to reuse, recycle and recover the product and our environment will be protected.

For further information please contact your dealer or distributor in your country. This product shall not be mixed or disposed with commercial waste.

Francais

Traitement des appareils électriques et électroniques en fin de vie (Applicable dans les pays de l'Union Européenne seulement)

Ce symbole (poubelle interdite) apposé sur le produit indique qu'en fin de vie ce produit ne doit pas être traité avec les déchets ménagers.

Il doit être remis à un point de collecte approprié pour le recyclage des appareils électriques et électroniques.

Pour de plus amples informations, veuillez contacter le service de collecte des déchets ménagers local. Ce produit contient des substances potentiellement dangereuses qui peuvent avoir des effets néfastes sur l'environnement et la santé humaine. En veillant à la mise au rebut correcte de ce produit, vous contribuerez à assurer le traitement, la récupération et le recyclage de ce produit et à protéger l'environnement.

Pour de plus amples informations veuillez contacter votre revendeur ou distributeur local. Ce produit ne doit pas être traité avec les déchets d'entreprises.

Espanol

Disposicion sobre Residuos de aparatos eléctricos y electronicos (Aplicable solo a la Union Europea)

Los productos identificados con este simbolo (papelera tachada) no deben eliminarse como residuos domésticos una vez finalizada su vida útil.

Este producto debe entregarse a un punto de recogida de la comunidad local para su recuperacion y reciclado.

Para mayor informacion, sirvase ponerse en contacto con el Departamento de Disposicion de Desechos de su Ayuntamiento. El manejo inadecuado de los residuos supone riesgos para la salud humana o el medio ambiente. Con la reutilizacion, el reciclado de los materiales u otras formas de valorizacion de tales productos usted contribuye de manera importante a la proteccion de nuestro medio ambiente.

Para mayor informacion sirvase ponerse en contacto con el concesionario o distribuidor de su pais. Este producto no deber mezclarse ni desecharse junto con los residuos comerciales.

Deutsch

Entsorgung von elektrischen & elektronischen Produkten (Anzuwenden nur in den Landern der Europaischen Union)

Dieses Symbol (ausgekreuzte Mülletonne) auf dem Produkt bezeichnet, dass Altgeräte usw. nicht wie normaler Haushaltsabfall in den Müll gegeben werden dürfen, sondern zum Recycling an einer hierfür vorgesehenen Annahmestelle abzugeben ist.

Für nähere Informationen wenden Sie sich bitte an die für Müllentsorgung zuständigen örtlichen Behörden. Bei unsachgemäßer Entsorgung besteht das Risiko nachteiliger Auswirkungen auf Umwelt und Gesundheit durch potentiell gefährliche Substanzen. Durch Ihre Kooperation zur ordnungsgemäßen Entsorgung fördern Sie die Wiederverwendung, das Recycling und die Rückgewinnung von Stoffen und tragen zum Umweltschutz bei.

Für nähere Informationen wenden Sie sich bitte an Ihren Händler oder den zuständigen Vertrieb. Das Produkt darf nicht in den normalen Gewerbemüll gegeben werden.



**Dichiarazione
Declaration**

**FASEP 2000 srl
Via Faentina 96
50032 Ronta (Fi), Italy.**

-dichiara, sotto esclusiva responsabilità, che il sottoindicato prodotto é conforme alle direttive e norme indicate:
-declare, under own responsibility, that the below indicated equipment complies with the following norms and directives:

Tipo di prodotto / Type of equipment: equilibratrici/ wheel balancers
Modello, Nr di serie / Model, Serial nr.: vedi targhetta / see badge

UK Regulations

Direttiva macchine / Directive Machines:
Supply of Machinery (Safety) Regulations 2008

Bassa Tensione / Low Voltage Directive:
Electrical Equipment (Safety) Regulations 2016

Compatibilità Elettromagnetica / Electromagnetic Compatibility Directive:
Electromagnetic Compatibility Regulations 2016

UK Designated Standards (with the prefix BS)

**BS UNI EN ISO 12100:2010
BS EN 60204-1:2018
BS EN IEC 61000-6-3:2021
BS EN IEC 61000-6-1:2019,
BS ISO/IEC 17050-1:2010**

Ronta, Firenze

Data _____

FASEP 2000 srl
Fulvio Boni, Presidente

Persona autorizzata a costituire il Fascicolo Tecnico:
Fasep 2000 srl, Via Faentina 96 - Ronta, 50032 Borgo San Lorenzo (Fi)



**Dichiarazione di Conformità CE
EU-Declaration of Conformity
Déclaration CE de conformité
EU Konformitätserklärung
Declaración de Conformidad CE**

**FASEP 2000 srl
Via Faentina 96
50032 Ronta (Fi), Italy.**

- dichiara, sotto esclusiva responsabilità, che il sottoindicato prodotto è conforme alle direttive e norme indicate:
- declare, under own responsibility, that the below indicated equipment complies with the following norms and directives:
- déclare, sous propre responsabilité, que l'équipement ci-dessous indiqué est conforme aux normes et directives:
- erklärt unter eigener Verantwortung, dass die unten bezeichnete Ausrüstung mit folgenden Normen und Richtlinien übereinstimmt:
- declara, bajo exclusiva responsabilidad, que el producto abajo indicado es conforme a las normas y las directrices indicadas:

Tipo di prodotto / Type of equipment: equilibratrici / wheel balancers
Modello, Nr di serie / Model, Serial nr.: vedi targhetta / see badge

Direttive applicate / Applied CE-Directives

Compatibilità Elettromagnetica / Electromagnetic Compatibility Directive: **2014/30/UE**

Norme Armonizzate applicate / Applied Harmonised Standards

BS EN IEC 61000-6-3:2021, BS EN IEC 61000-6-1:2019, ISO/IEC17050-1:2020

Ronta, Firenze

Data _____

FASEP 2000 srl
Fulvio Boni, Presidente

Persona autorizzata a costituire il Fascicolo Tecnico:
Fasep 2000 srl, Via Faentina 96 - Ronta, 50032 Borgo San Lorenzo (Fi)